



Automatic Blade Control

Control Box Model 26

BULLSEYE 5MC Receiver



8261 State Route 235
Dayton, Ohio 45424 USA
Phone: (937) 482-0200
Fax: (937) 482-0030
www.apache-laser.com



Thank you for purchasing an Apache Technologies, Inc. product. Your control box and laser receiver are premium quality tools that has been designed and manufactured to provide years of reliable performance. The control box, receiver and accessories have been specifically designed for use in harsh machine mounted construction environments.

This manual is an important part of your purchase as it will familiarize you with the system and explain the numerous features that have been designed into it. Please read this manual thoroughly before using your system.

Please contact your Apache dealer or the Apache factory should you have questions regarding specific applications or if you require additional information.

Apache Technologies, Inc.
8261 State Route 235
Dayton, Ohio 45424 USA

Phone: (937) 482-0200
Fax: (937) 482-0030
Website: www.apache-laser.com
E-mail: sales@apache-laser.com
service@apache-laser.com

Please record your product information below. This will assist you if there are any questions regarding warranty or service.

PRODUCT(S): _____
SERIAL NUMBER(S): _____
DATE OF PURCHASE: _____
PURCHASED FROM: _____
PHONE: _____



CE Declaration of Conformity

We herewith declare, in exclusive responsibility, that the instruments

- **Bullseye 3+, 5+, 5MC, 6**
- **Control Box CB26, CB24+**

were developed, designed and manufactured to conform with the

- Council Directive 89/336/EEC (Electromagnetic Compatibility)

including their amendments up to the date mentioned below.

Equipment Type / Environment: Measurement, Control, and Laboratory Equipment

The following harmonized standards were applied:

- EN61326: 1997 +A1: 1998 + A2: 2001
Electromagnetic compatibility (EMC)
Requirement for electrical equipment for measurement, control and laboratory use
- EN61000-3-2: 2000
Mains Harmonic Emissions
Single Phase < 16A / Phase
- EN61000-3-3: 1995 +A1: 2001
Mains Voltage Fluctuations and Flicker Emissions
Single Phase < 16A / Phase

We, the undersigned, hereby declare that the equipment specified above conforms to the above Directive(s).

Apache Technologies, Inc.
8261 State Route 235
Dayton, OH 45424 USA

Robert G. Conner
President

23 July 2004

Notice to Our European Union Customers

For product recycling instructions and more information, please go to: www.trimble.com/environment/summary.html

Recycling in Europe

To recycle Trimble WEEE, call: +31 497 53 2430, and ask for the "WEEE associate," or

mail a request for recycling instructions to:

Trimble Europe BV
c/o Menlo Worldwide Logistics
Meerheide 45
5521 DZ Eersel, NL



Warranty

Apache Technologies receivers and control boxes are warranted to be free of defects in material and workmanship for a period of two years. This warranty period is twenty-four months from the date the product is delivered from the dealer to the purchaser or is put into service by a dealer as a demonstration unit or rental unit. Electric cables and other allied equipment are warranted for a period of ninety days.

Please return the included warranty card as this will expedite any warranty service that may be required. Please retain your warranty information and proof of purchase. If a warranty card is not on file, proof of purchase must accompany your request for warranty repair.

Any evidence of abuse, misuse, alteration, accident or negligent use, or an attempt to repair products by unauthorized personnel or with parts other than those provided by Apache Technologies automatically voids the warranty.

The user of the product is expected to follow all operating instructions, periodically checking the instrument and the work as it progresses.

Apache Technologies liability under this warranty is limited to repairing or replacing any product returned to an authorized service center for that purpose. The foregoing states the entire liability of Apache Technologies regarding the purchase and use of its product and they shall not be held responsible for any consequential loss or damage of any kind.

This warranty is in lieu of all other warranties, expressed or implied, and constitutes all of Apache Technologies liability with respect to merchandise sold by it.

Contents

CONTROL BOX MODEL 26

System Description	2
Controls and Displays	3
Configuration	6
Operation	9
System Wiring	11

BULLSEYE 5MC

System Description	14
Controls and Displays	14
Installation	15
Maintenance and Care	16
Specifications	16
Meaning of Symbols	17
Safety	17
Warranty	18
CE Declaration of Conformity	Inside Back Cover

System Description

Apache Automatic Blade Control is used on construction grading machinery to automatically control the blade in earthmoving and grading applications. It is also used on agricultural drainage and land leveling machinery.

A BULLSEYE laser receiver mounts above the cutting edge of the blade. A control box and a hydraulic installation kit tie into the machine's hydraulic system. Grade information from a rotating laser is processed and automatically directs the machine's hydraulics to maintain the elevation of the blade. The higher the rotation speed of the laser, up to 1200 RPM, the better the system performance will be.

Control Box:

The control box mounts in the cab. The operator can easily select automatic or manual control. An LED display indicates the position of the blade. Adjustments can be made for deadband or accuracy from 0 to 1.50 inches (3.8 cm) in 1/10 inch (0.25 cm) increments. Adjustment of the hydraulic speed (gain) is also possible in the cab. Additional adjustments provide optimum blade control performance for various types of machinery and conditions.

The control box is designed to work with many types of hydraulic valves, from on/off (bang-bang) solenoid valves to fully proportional valves.

Receivers:

All BULLSEYE receivers feature 360 degree laser reception and work with all common rotating lasers. Proprietary and patented advanced proportional photocell technology assures maximum accuracy. All units are waterproof and construction tough.

BULLSEYE 5+, 5MC, and 6 are designed for automatic blade control. Models 5+ and 6 can also be used as stand alone display receivers on excavating and grading equipment. Please refer to the BULLSEYE 5+ and 6 manuals for more detailed information. Information on the BULLSEYE 5MC begins on page 14.

CONTROL BOX MODEL 26

Controls and Displays

Front View

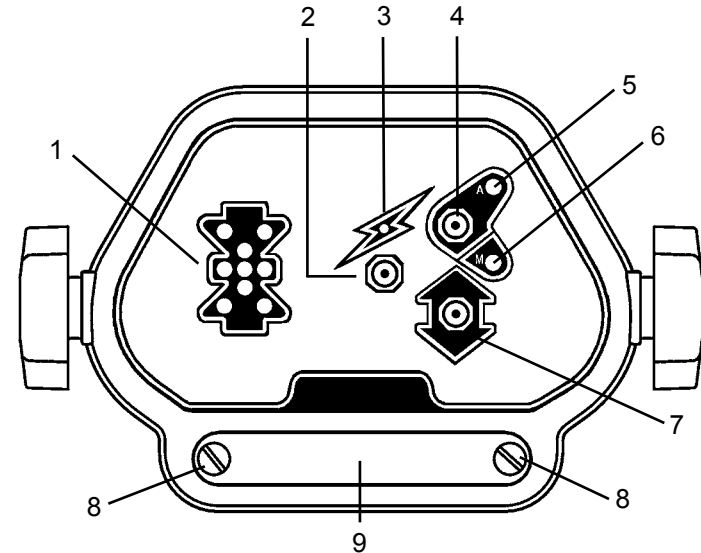

1. LED grade display
2. Power ON / OFF switch
3. Power ON indicator
4. Automatic / Manual toggle switch
5. Automatic ON indicator
6. Manual ON indicator
7. Raise / Lower toggle switch
8. Access panel thumbscrews
9. Access panel

Controls and Displays

Switch Panel

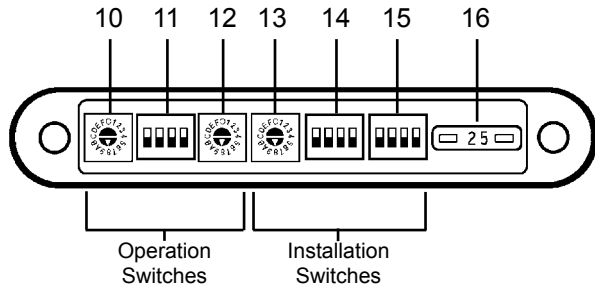

Operation Switches:

10. Rotary switch - On-Grade Deadband selections
(Default setting is "8".)
11. Dip Switch 4-way - Performance selections
(Default setting is all in the OFF position.)
12. Rotary switch - Valve gain (speed)
(Default setting is "8".)

Installation Switches:

13. Rotary switch - Valve balance (raise/lower)
 14. Dip Switch 4-way - Valve set-up
 15. Dip Switch 4-way - Valve drive selector
16. Fuse, 25 amp

The 3 left side switches (10, 11, 12) are used by the operator to set operating functions. Detailed information starts on page 6.

The 3 right side switches (13, 14, 15) are used during installation for specific valves and machine settings. **These should not be changed by the operator.** Contact the installation technician for additional information if required.

Controls and Displays

Rear View

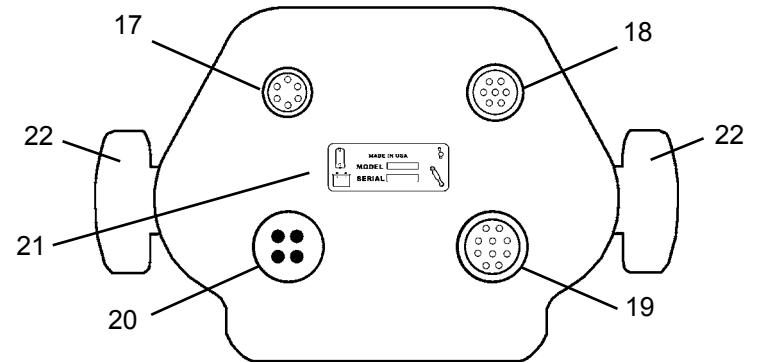

17. 6-socket connector - BULLSEYE communication
18. 7-socket connector - optional remote switch
19. 10-socket connector - hydraulic valve outputs
20. 4-pin connector - machine power input
21. Identification / serial number label
22. Mounting knobs for bracket

Configuration

The control box has been designed to meet different machinery and application requirements. The system operation is a function of deadband setting, gain selection, laser RPM, machine speed, hydraulic pressure and flow, installation settings, and general site or field conditions. The user selectable factors of the control box are the deadband, the gain and the LED displays. Two rotary switches are provided for selecting the on-grade deadband (10) and the gain (12), while a dip switch (11) provides for LED display selections. These switches are located behind the access panel on the bottom front of the control box. Turn the 2 thumbscrews counterclockwise and remove the panel from the box housing to access these switches.

On-Grade Deadband (Accuracy) Selection Switch (10):

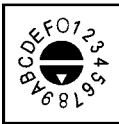

The on-grade deadband rotary switch (10) provides 16 positions of deadband selection with "0" being the smallest and increasing clockwise to "F" which is the largest. The table below lists the corresponding on-grade deadband for each switch position. Each number or letter setting represents an increment of one-tenth inch (0.10 inch) or approximately 2.5 mm.

	0	1	2	3	4	5	6	7
in.	0	0.1	0.2	0.3	0.4	0.5	0.6	0.7
mm	0	2.5	5.1	7.6	10.2	12.7	15.2	17.8

	8	9	A	B	C	D	E	F
in.	0.8	0.9	1.0	1.1	1.2	1.3	1.4	1.5
mm	20.3	22.9	25.4	27.9	30.5	33.0	35.6	38.1

Examples:

The deadband setting of "5" would correspond to ½ in. (12.7 mm).
The deadband setting of "A" would correspond to 1.0 in. (25.4 mm).

The default on-grade deadband is set to "8" or 0.8 in. (20.3 mm).

Configuration

Dip Switch (11) Settings:

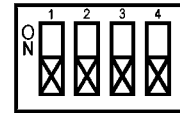

The dip switch panel consists of 4 individual switches. The up position is ON and the down position is OFF. The function of each switch and their factory default settings are as follows:

Switch #	Function	Position	Default Position
1	Laser strike averaging off	OFF	OFF
	Laser strike averaging on	ON	
2	Receiver LED's disabled	OFF	OFF
	Receiver LED's disabled	ON	
3	Control Box LED's bright	OFF	OFF
	Control Box LED's dim	ON	
4	Linear Gain	OFF	OFF
	Exponential Gain	ON	

1. Laser strike averaging - This switch is normally in the OFF position. It is turned ON only when required for long range applications where the rotating laser may be relatively unstable due to environmental or jobsite conditions.
2. Receiver LED disable - The receiver LED's will be displayed when the switch is in the default OFF position. There will be no display on the receiver LED's when the switch is in the ON position.
3. Control Box LED's - The default OFF position and normal operating setting for the control box is LED's "bright". The control box LED's can be set to dim by changing this switch to the ON position. This may be preferred at night or in low light conditions.
4. Linear or exponential gain is usually set depending on the characteristics of the spool in the hydraulic valve. Do not change this setting without consulting the installation technician.

Configuration

Gain Selection Switch (12):



The gain selection rotary switch (12) provides sixteen positions with "0" being the slowest reacting and increasing clockwise to "F" which is the fastest reacting.

When the receiver is in the on-grade deadband, no correction signals are sent to the valve. Immediately after the receiver moves outside of the on-grade deadband, signals are sent to correct the elevation. As the receiver moves further away from the on-grade deadband, the valve continues to open until the valve is in the 100% open state. The distance between this initial opening of the valve and the 100% open state is controlled by the gain.

The default gain setting is "8". Field adjustments may be necessary due to the many other variables in the system operation and jobsite requirements. If the system becomes unstable, overreacting between above grade and below grade, increase the deadband setting or decrease the gain setting.

Operation

Power ON / OFF Switch:



Push the power switch (2) once to turn the system on. All LED's on the box will turn on for a brief period. The red power on indicator LED (3) will stay lit to indicate the power is on. Turning the box on will also turn the receiver on. Push the power switch again to turn the system off.

LED grade display:

When a laser strikes the receiver, there are 5 possible positions of grade information indicated.

- High Coarse* - 3 top red LED's forming down arrow
- High Fine* - 3 top red LED's and 3 green on-grade LED's
- On-Grade* - 3 green LED's forming horizontal bar
- Low Fine* - 3 bottom red LED's and 3 green on-grade LED's
- Low Coarse* - 3 bottom red LED's forming up arrow

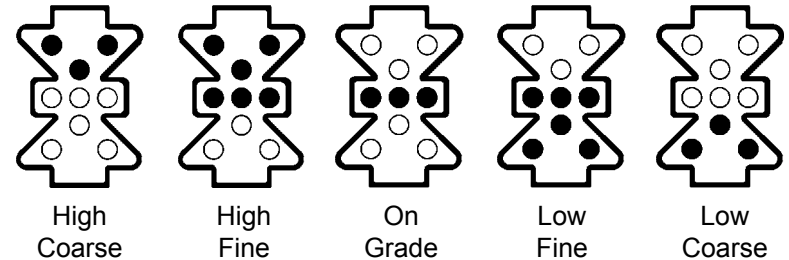

If the laser moves off the reception range of the receiver, an out-of-beam will be indicated on the LED's as follows. If the last laser reception was on the bottom of the receiver, the top 3 LED's will flash indicating to move the receiver down. If the last laser reception was on the top, the bottom 3 LED's will flash indicating to move the receiver up. The out-of-beam indication lasts for 2 minutes.

Operation

Automatic / Manual Toggle Switch (4):



Automatic: Push the switch to the top (up) position for automatic mode, which is indicated with an "A". The switch will return to the neutral position. The green LED will turn on confirming that the box is in the automatic mode. When the BULLSEYE receives a laser strike, the box will send the appropriate signals to the valve to raise or lower the implement to obtain and maintain an on-grade position. If the receiver is not receiving a laser strike, it must be moved within the reception range to begin corrections.

Manual: Push the switch to the bottom (down) position for manual mode, which is indicated with an "M". The switch will return to the neutral position. The amber LED will turn on confirming that the box is in the manual mode. When the BULLSEYE receives a laser strike, the box will display the grade information on the LED's but will not send signals to the valve. The operator may use the raise/lower toggle switch, the optional remote raise/lower switch, or the machine lever to raise or lower the implement.

Raise / Lower Toggle Switch (7):



This switch raises or lowers the implement. When in the manual mode, the switch acts just like the manual lever. To raise the implement, push the switch up. To lower the implement, push the switch down. When released, the switch will go back to the center neutral position.

When the system is in the automatic mode the manual raise and lower switch will override the automatic setting when it is activated and raise and lower the implement. When it is released, the automatic mode will resume normal operation.

System Wiring

All cables should be properly installed. Cables should be attached to the machine a minimum of every 2 to 3 feet (.6 to 1.0 meter) or less to try to eliminate cable movement and possible abrasion damage. Special care should be taken at flex points to ensure the cable moves freely and does not rub on other hoses, fittings, or the machine. Provide for adequate cable length to avoid pinching, stretching, and tight bending. Also, cables should not be clamped to pipes or hoses that will be exposed to high temperatures.

Connect the 4-socket connector on the power cable to the 4-pin connector on the box and connect the terminal ends to the machine's battery. The red terminal is for the positive post and the black is for ground. The box has reverse polarity protection in case the terminals are connected improperly.

Connect the 6-pin receiver cable end to the 6-socket connector on the box. Connect the 7-socket receiver cable end to the 7-pin connector on the bottom of the BULLSEYE receiver. If a coil cord and junction box are used, ensure the proper connections at the junction box.

Connect the 10-pin valve cable to the 10-socket connector on the box and connect the open-ended wires to the valve following the directions for the valve.

Optional Remote Switch

Attach the switch end at a convenient location for the operator, usually on the existing raise lower lever. Route the cable to avoid any damage. Connect the 7-pin remote switch connector to the 7-socket connector on the box. The remote switch is configured to operate the same as on the control box - the up position is automatic, and the down position is manual. The switch also has the option for raise/lower switch. If installed, raise will be the up position and lower will be the down position.

System Wiring

Cable Configurations:

Receiver Cable - powers the receiver and communicates grade information between the receiver and the control box.

RECEIVER CABLE			
Function	Control Box	Receiver	Wire
	6 Socket	7 Socket	Color
Power	A	A	Red
Communication	B	B	Green
Communication	C	C	White
Ground (Signal)	D	D	Black
High Power Return	E	E	N/C
High Power Supply	F	F	N/C
	N/A	G	N/C

Power Cable - supplies power to the system. The control box supports both 12 and 24 volt machine systems.

POWER CABLE		
Function	Control Box	Wire
	4 Pin	Color
Machine Ground	A	Black
Machine Ground	B	Black
Machine Power	C	Red
Machine Power	D	Red

System Wiring

Cable Configurations:

Valve Cable - communicates grade information between the control box and the hydraulic valve.

VALVE CABLE			
Function	Function	Control Box	Wire
		10 Socket	Color
PV Valve	PC / PT Valve		
Not Used	Lower Valve	A	Blue
D.F. Diagnostic	Raise Valve	B	Green
Switched Power	Switched Power	C	Red
Load Sense	Load Sense	D	Orange
PV Signal	Not Used	E	White
		F	N/C
		G	N/C
		H	N/C
Ground	Ground	I	Black
Ground	Ground	J	White/Black

Remote Switch Cable - optional accessory that extends the raise/lower and auto/manual switches via cable.

REMOTE SWITCH CABLE		
Function	Control Box	Wire
	7 Socket	Color
Auto/Manual	A	Orange
Raise/Lower	B	Green
Aux. Remote 0	C	N/C
Aux. Remote 1	D	N/C
N/C	E	N/C
Remote Switch Power	F	Red
Remote Switch Ground	G	Black

BULLSEYE 5MC

System Description

The Apache BULLSEYE 5MC laser receiver is a rugged, electronic receiver that detects laser light generated by rotating lasers. The unit is designed to work with all common rotating lasers and will detect both visible and invisible beams.

The 5MC is designed to be installed with an Apache Control Box for automatic control on certain grading machines. Power to the 5MC receiver comes from the control box that is connected to the machine's power.

The receiver does not have any on-board switches, but settings are made at the control box. A mini built-in LED display provides grade elevation position, plus high and low lost beam indications.

Controls and Displays

Front View

1. Aluminum cast upper and lower housings.
2. Polycarbonate housing - protects the electronics.
3. Receiving Window - four sets of photocells equally spaced to allow 360 degree reception.
4. Mini LED array displays the blade position.
5. Mounting Knobs - large, front facing knobs attached to stainless steel clamps allow for quick and easy installation to mast.
6. Connector - accepts the cable connection from the control box.

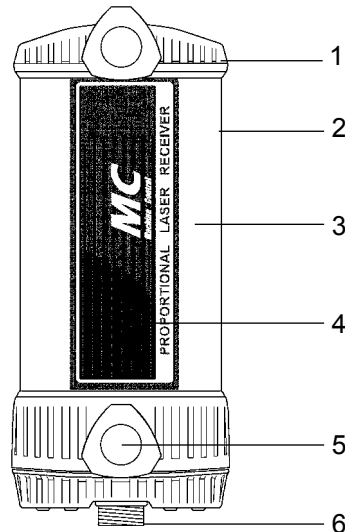

Installation

The BULLSEYE 5MC receiver mounts to round masts from sizes 1.66" to 2.00" O.D. (42 to 50 mm) and to 1 1/2" (38 mm) square tube.

The model STM1 shock mounted telescoping mast is ideally suited for machine control applications. The mast allows the receiver to be positioned above the machinery for unobstructed laser reception. The mast has a 4-foot (1.2 m) telescoping adjustment range with an English/Metric scale for positioning at known elevations. Built-in shock mounts on all four sides provide excellent damping of the laser receiver in rough operating conditions.

Set the laser up in an appropriate location for receiver visibility and efficient machine operation and turn it on.

Position the machine so the blade is set to the desired finished elevation, typically on a benchmark or hub stake.

Mount the receiver to the mast.

Turn the system on and choose a narrow on-grade deadband for set-up (Switch 10, position 1 or 2). Always note the previous setting before making any changes. Slide the receiver up or down until on-grade is indicated. It may be necessary to adjust the height of the laser. Reset the on-grade deadband to the desired accuracy.

Face the LED display toward the operator and tighten the clamps.

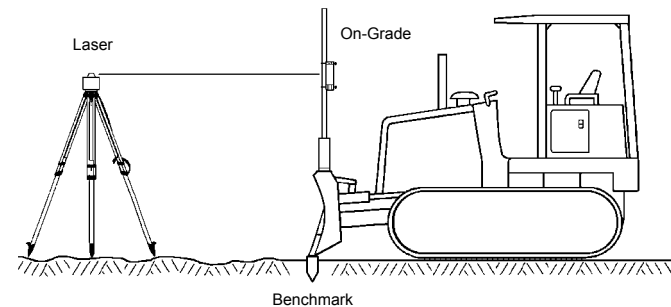

Maintenance and Care

The user of this product is expected to follow all operating and safety instructions of this manual and of the machinery operator's manual.

Do not wipe dust or dirt off the receiver or control box with a dry cloth as scratching could occur. Use only soap and water with a soft cloth on all external surfaces and windows.

Transport the instruments in their original cases.

Inspect cables daily to ensure there is no excessive wear, especially at pivot points. Check for crimps or cuts in the wire insulation.

Specifications - CB26

On-Grade LED's	Green
High / Low LED's	Red
Operating Voltage	10 to 30 Volts DC, reverse polarity protected
Electrical Connection	Standard military type
Valve Compatibility	Proportional Time (On/Off), Proportional Current, and Proportional Voltage
Maximum Current	5 Amps per coil
Remote Switch Option	Raise/Lower, Auto/Manual switches
Weight	5 lbs. (2.25 kg)
Dimensions	7.0 x 5.3 x 4.8 in. (178 x 134 x 120 mm)

Specifications - BULLSEYE 5MC

Beam Reception	360 degrees
Operating Range	Over 1500 ft. (460 m) radius, laser dependent
Laser RPM	Minimum - 105 ; Maximum - 1200
Vertical Reception	6.75" (170 mm)
Accuracy	Set at Control Box
Power	10-30 VDC
LED Display	Mini display for set-up Red - Hi, Low, On-grade,
Out of Beam Indication	High and Low
Dimensions	(LxWxD) 13.50 x 5.58 x 5.88 in. (343 x 142 x 149 mm)
Mounting Pipe	1.66" to 2.00" O.D. round tube (42 mm to 50 mm) and 1 1/2" (38 mm) square tube
Operating Temperature	-4° F to 140° F (-20° to +60° C)

**Specifications subject to change without notice*

Meaning of Symbols



WARNING: Indicates a potential hazardous situation, which could result in death or serious injury.

CAUTION: Indicates a potentially hazardous situation, which could result in a minor or moderate injury and/or material, financial, or environmental damage.

NOTE: Important information to enable the product to be used in a correct and efficient manner unrelated to safety.

Safety

WARNING: Do not remove the back panel of the control box. The back panel is to be accessed by authorized Apache Technologies service personnel only.

WARNING: Be aware of all overhead obstructions and electrical power lines. The receiver and mast may be higher than the machinery. Remove when transporting.

CAUTION: Ensure all equipment is properly installed, the BULLSEYE receiver is secured in its mounting position, and all cables connections are tight and secure.

CAUTION: The person responsible for the instrument must ensure that it is used in accordance with the instructions. This person is also accountable for the training of personnel who use the instruments and for the safety of the equipment when in use.

NOTE: Environmental Limits: Suitable for use in an atmosphere appropriate for human habitation (no protection in an aggressive or explosive environment). Can be used in rain for short periods. Refer to specifications for temperature ranges.

