



Automatic Blade Control

TORNADO F2

Dual Control Box Laser System



8261 State Route 235
Dayton, Ohio 45424 USA
Phone: (937) 482-0200
Fax: (937) 482-0030
www.apache-laser.com



Thank you for purchasing an Apache Technologies, Inc. product. Your control box and laser receiver are premium quality tools that has been designed and manufactured to provide years of reliable performance.

This manual is an important part of your purchase as it will familiarize you with the system and explain the numerous features that have been designed into it. Please read this manual thoroughly before using your system.

Please contact your Apache dealer or the Apache factory should you have questions regarding specific applications or if you require additional information.

Apache Technologies, Inc.
8261 State Route 235
Dayton, Ohio 45424 USA

Phone: (937) 482-0200
Fax: (937) 482-0030
Website: www.apache-laser.com
E-mail: sales@apache-laser.com
service@apache-laser.com

Please record your product information below. This will assist you if there are any questions regarding warranty or service.

PRODUCT(S): _____
SERIAL NUMBER(S): _____
DATE OF PURCHASE: _____
PURCHASED FROM: _____
PHONE: _____



CE Declaration of Conformity

We herewith declare, in exclusive responsibility, that the instruments

- **Bullseye 3+, 5+, 5MC, 6**
- **Control Box CB26, CB24+, CB52**

were developed, designed and manufactured to conform with the

- Council Directive 89/336/EEC (Electromagnetic Compatibility)

including their amendments up to the date mentioned below.

Equipment Type / Environment: Measurement, Control, and Laboratory Equipment

The following harmonized standards were applied:

- EN61326: 1997 +A1: 1998 + A2: 2001
Electromagnetic compatibility (EMC)
Requirement for electrical equipment for measurement, control and laboratory use
- EN61000-3-2: 2000
Mains Harmonic Emissions
Single Phase < 16A / Phase
- EN61000-3-3: 1995 +A1: 2001
Mains Voltage Fluctuations and Flicker Emissions
Single Phase < 16A / Phase

We, the undersigned, hereby declare that the equipment specified above conforms to the above Directive(s).

Apache Technologies, Inc.
8261 State Route 235
Dayton, OH 45424 USA

Robert G. Conner
President

23 July 2004

Notice to Our European Union Customers

For product recycling instructions and more information, please go to: www.trimble.com/environment/summary.html

Recycling in Europe

To recycle Trimble WEEE, call: +31 497 53 2430, and ask for the "WEEE associate," or

mail a request for recycling instructions to:

Trimble Europe BV
c/o Menlo Worldwide Logistics
Meerheide 45
5521 DZ Eersel, NL



Notes

Contents

CONTROL BOX CB52

1	Before You Start	2
2	Meaning of Symbols	2
3	Warnings / Safety	3
4	System Description	4
5	Quick Start - Setup	6
6	Controls and Displays	8
6.1	Front View	8
6.2	Rear View	10
6.3	LCD - Dual Elevation	11
6.4	LCD - Elevation and Slope	12
6.5	Sensor Position Window	13
6.6	LED Display	13
7	Operation	14
7.1	Select Operating Modes	15
7.2	Slope Sensor Bench	15
7.3	Auto / Manual	16
7.4	Raise / Lower	16
7.5	Elevation / Slope Offset	17
7.6	Elevation / Slope Matching	18
7.7	Slope Reverse (Flip)	19
7.8	Link	20
7.9	Audio Alerts	21
7.10	Remote Switches	21
8	User Setup	22
8.1	Brightness / Contrast	23
8.2	Deadband	24
8.3	Valve Gain	25
8.4	Reference Elevation	26
8.5	Units of Measure	26
8.6	Store and Recall	27
8.7	Lock Settings	28
9	Self Diagnostics	29
10	Specifications	30
11	Maintenance and Care	30
12	Warranty	31
	CE Declaration of Conformity	Inside Back Cover

1 Before You Start

Before you start using the system, ensure the installation was complete and the valves were calibrated.

Do not operate the system unless you are fully trained on this equipment and machinery.

Ensure the laser transmitter is correctly set up in a suitable location and that it is turned on.



NOTE: The left and right sides of the machine are referenced while seated in the operator's seat, facing the normal direction of travel.

2 Meaning of Symbols



WARNING: Indicates a potential hazardous situation, which could result in death or serious injury.



CAUTION: Indicates a potentially hazardous situation, which could result in a minor or moderate injury and/or material, financial, or environmental damage.



NOTE: Important information to enable the product to be used in a correct and efficient manner unrelated to safety.

3 Warnings / Safety



NOTE: The user of this product is expected to follow all operating and safety instructions of this manual and of the machinery operator's manual. Perform periodic checks of the product's performance. The manufacturer or its representatives assume no responsibility for results of the use of this product including any direct, indirect, consequential damage, and loss of profits. Check your work frequently.



NOTE: Changes to the technical setup configuration and system components should only be done by qualified technicians. Do not make modifications, repairs or adjustments to any electrical or hydraulic system unless you are competent or working under competent supervision.



WARNING: Equipment may extend beyond the extents of the blade or other implements. Maintain adequate clearance from people and objects when operating the equipment.



WARNING: Never leave the system in automatic mode while unattended.



WARNING: Always place the blade on the ground when not in use.

NOTE: At any time, the power switch can be toggled down to the OFF (O) position to turn the power off.



WARNING: Do not remove the back panel of the control box. The back panel is to be accessed by authorized Apache Technologies service personnel only.



WARNING: Be aware of all overhead obstructions and electrical power lines. The receiver and mast may be higher than the machinery. Remove when transporting.



CAUTION: Ensure all equipment is properly installed, the BULLSEYE receiver is secured in its mounting position, and all cables connections are tight and secure.



CAUTION: The person responsible for the instrument must ensure that it is used in accordance with the instructions. This person is also accountable for the training of personnel who use the instruments and for the safety of the equipment when in use.



NOTE: Environmental Limits: Suitable for use in an atmosphere appropriate for human habitation (no protection in an aggressive or explosive environment). Can be used in rain for short periods. Refer to specifications for temperature ranges.

4 System Description

The TORNADO F2 Dual Automatic Blade Control System uses a CB52 Control Box, BULLSEYE® laser receivers, cables, optional remote switches, and a hydraulic kit to automatically control construction or agricultural grading machinery for earthmoving and grading applications.

Reference elevation from a rotating laser is received by the BULLSEYE receivers and sent to the control box. Elevation information is processed and automatically directs the hydraulic valves to maintain the elevation of the blade when in automatic mode.

Machine architecture can be set for lift and tilt control, a typical bulldozer arrangement, or for lift and lift control, a typical machine architecture for a motor grader. In addition the system can be set to control the elevation of two independent implements with receivers, such as tandem carry-all type scrapers.

Elevation control may be combined with slope control with certain BULLSEYE receivers that contain internal slope sensors. These slope sensors control the slope of the blade relative to the machine, unlike slope lasers, which provide a slope relative to the laser transmitter.

Control Box:

The control box mounts in the cab and is cable connected to machine power, the BULLSEYE receivers and the hydraulic valves. Remote switches may also be connected. The operator selects operating modes based on the job and equipment.

An LCD indicates system and configuration status and an LED display indicates grade information for each side. Automatic or manual modes are indicated with LED's. An audible beep is also emitted when entering commands or changes.

Adjustments can be made for deadband (accuracy) and hydraulic speed (gain). Offset elevation, reference elevation, units of measure, and screen brightness and contrast can also be selected or adjusted by the operator. Setups for four different applications, preferences, or machines can be stored and recalled.

4 System Description

Receivers:

All BULLSEYE receivers feature 360 degree laser reception and work with all common rotating lasers.

BULLSEYE models 3+, 5+, 5MC, and 6 are designed for automatic blade control and will work with the CB52.

Models 5+ and 6 incorporate internal slope sensors that can be used for blade slope control on most dozers. Elevation and slope are controlled from a single receiver.



NOTE: The internal slope sensors must be calibrated to the machine before use.

Model 3+ has limited proportional control capability and therefore limited elevation offset and on-grade matching capability.

Models 3+, 5+ and 6 can also be used as stand alone display receivers.

Please refer to the specific BULLSEYE manuals for more detailed information.

Optional Remote Switches:

Multi-switch remote switches can be configured to operate similar to the multi-switches on the control box. Typically the remote switches are used to select automatic or manual control. Raise or lower implement, elevation and slope offset and matching functions may be configured during installation.

A single remote switch is used for Lift and Tilt applications. A dual remote switch is used for Dual Lift applications.

When mounted with the cable downward and the switch facing inward, toggle forward is Automatic, toggle backward is Manual, toggle up is Raise, and toggle down is Lower.



NOTE: In this manual, when reference is made to multi-switches, it refers to the multi-switches on the control box unless otherwise noted.

5 Quick Start - Setup

To ensure the machine is grading to the correct elevation, the cutting edge must be benched over a point with a known elevation relative to the laser beam reference. This point is known as a benchmark. The machine must be benched every time the laser transmitter is setup.

To bench the system with a level laser, elevation sensors, and manual masts, complete the following steps:

1. Toggle the power switch in upward direction to turn the system on. Ensure the system is in manual control. Toggle the multi-switches inward for manual control. Ensure the system is in dual elevation operating mode. Refer to § 7.1
2. Place the point of the blade that is under the receiver on the benchmark. Make sure you do not move the benchmark. If necessary, place the blade next to the benchmark.



NOTE: For best accuracy, bench the system with the blade in the normal working position. Typically the blade should be on the ground and level with the tracks of the machine.

3. Level the cutting edge of the machine using a spirit level.
4. Manually move the right mast or receiver up or down until the receiver indicates on-grade. Tighten the receiver/mast.
5. Manually move the left mast or receiver up or down until the receiver indicates on-grade. Tighten the receiver/mast.

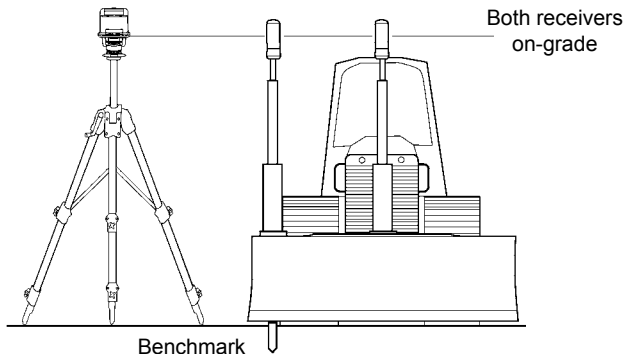

5 Quick Start - Setup

6. At the control box, press in and hold each multi-switch for one second to adjust the on-grade position to the current laser beam strike. The elevation value will go to 0.00.

7. Enter the User Setup Menu. Toggle the power/setup switch to the up position for approximately one second until the User Setup Menu appears.

8. Select deadband or accuracy. When in the User Setup Menu, rotate or toggle the multi-switch until the deadband icon is highlighted. Press in the multi-switch to enter. Select the appropriate deadband for the job required and the conditions. Press in or toggle the multi-switch to exit the function. Press in again to exit the User Setup Menu. (Refer to the User Setup section for additional information.)

9. Move the machine to the work area. Ensure the receiver is in the laser beam.

10. Switch the system from manual to automatic mode by toggling both control box multi-switches in the outward direction. The "A" LED's will come on confirming auto mode.

11. Grade a small area at the benched elevation and check that the blade is finishing to grade.



WARNING: Always turn the system to manual before leaving the operating platform. Turn to manual by toggling both control box multi-switches in the inward direction

12. Use a grade rod and laser detector to check the grade.

13. Make passes around the work area. If cuts become too large, temporarily raise the control set point by rotating the multi-switch. Increase or decrease the offsets to adjust the amount of cut, as required.

14. To turn the system off, toggle the power switch in the downward (o) direction. The current settings will be retained the next time the system is turned on. (Allow 30 seconds after changes for the box to save changes before powering off.)

6 Controls and Displays

6.1 Front View

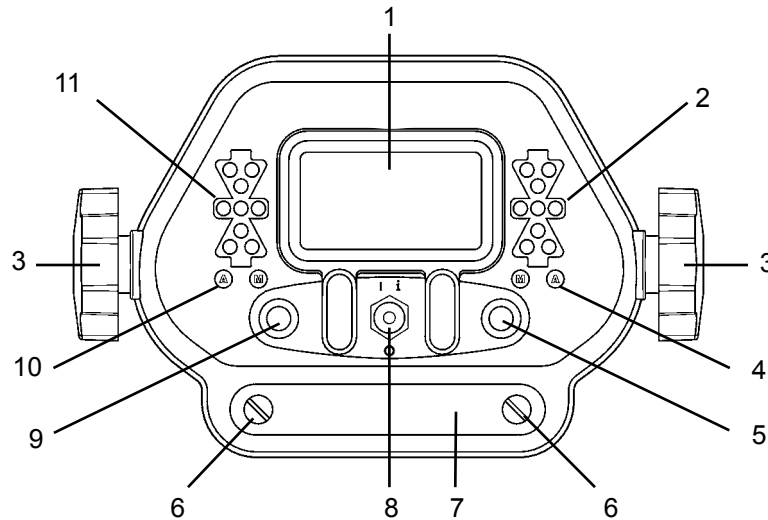

1. Liquid Crystal Display (LCD) - indicates operating and configuration information and system status. Menus are displayed during setup.
2. Right Grade LED's - green bar indicates on-grade, red arrows indicate direction to grade for right side. Blinking red arrows indicate lost beam and direction to move to find beam.
3. Mounting Knob - secures control box to mounting bracket.
4. Right Auto/Manual LED's - green "A" indicates Automatic or amber "M" indicates Manual is selected on right side.
5. Right Multi-Switch - left/right movement selects Auto/Manual control and up/down movement enables Raise/Lower implement. Rotation increases/decreases control set point. Pressing in enables elevation and slope matching. Navigates User Setup menu.

6 Controls and Displays

6. Access panel thumbscrew.
7. Access panel cover plate - panel contains a fuse and a rotary switch and DIP switch used for installation and factory setups.
8. Power / Setup Switch - turns power on and off. Toggle switch upward (I i) to turn power on. Toggle switch downward (o) to turn power off. Enables changing operating modes and entry into configuration modes. Enables entry into Help screens.
9. Left Multi-Switch - left/right movement selects Auto/Manual control and up/down movement enables Raise/Lower implement. Rotation increases/decreases elevation. Pressing in enables elevation and slope matching. Navigates User Setup menu.
10. Left Auto/Manual LED's - green "A" indicates Automatic or amber "M" indicates Manual is selected on left side.
11. Left Grade LED's - green bar indicates on grade, red arrows indicate direction to grade for left side. Blinking red arrows indicate lost beam and the direction to move to find beam.

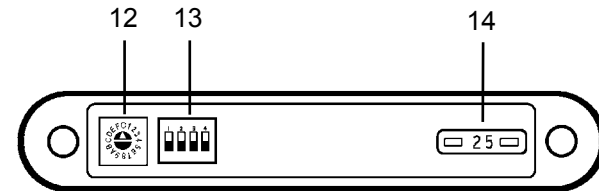

Access panel

12. Rotary Switch - used for factory setup. Default position is "0".
13. DIP Switch - used for installation and factory setup. Default position is all switch bats down (off).
14. Fuse - 25 amp, auto style.

6 Controls and Displays

6.2 Rear View

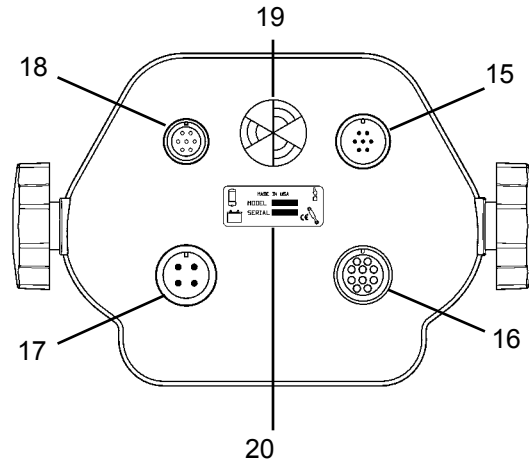

15. 7-pin connector - optional remote switch.
16. 10-pin connector - dual hydraulic valve output.
17. 4-pin connector - machine power input.
18. 7-pin connector - BULLSEYE receiver communication.
19. Beeper with adjustable volume control - rotate to increase or decrease volume. Single beep is activated when switch command is accepted. Double beep activated when switch command is not available, incorrect or not accepted.
20. Identification / serial number label / cable function symbols.

6 Controls and Displays

6.3 LCD - Dual Elevation Operating Mode

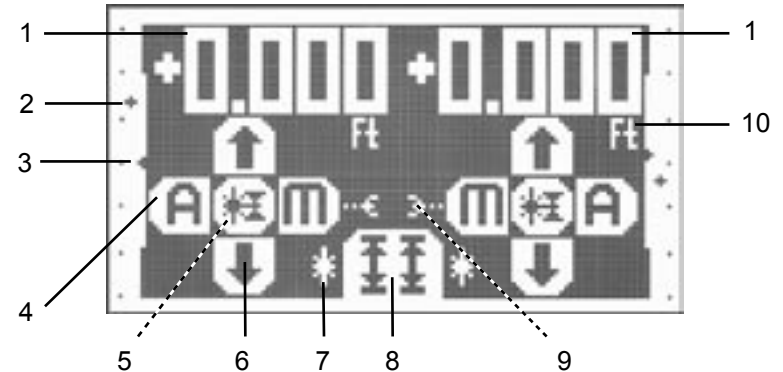

1. Reference Elevation - indicates the reference elevation that is set for the right and left side. Shown in units selected in User Setup.
2. Sensor Position Indicator - shows position of laser strike relative to the vertical reception range of the receiver. Left and right side display. Indicator will blink when laser strike is lost. See additional description in § 6.5.
3. Elevation Control Set Point - shows where on-grade is set relative to vertical reception range. Left and right side display.
4. Automatic / Manual switch direction indicator. Left and right side display. Outward is Automatic; Inward is Manual. (LED below the grade display LED's indicates current selection.)
5. Multi-switch function icon - pressing in enables elevation matching and laser strike centering. Rotation changes elevation control set point.
6. Raise / Lower switch direction indicator. Left and right side display. Upward is Raise; Downward is Lower.
7. Control Source Indicator - starburst icon indicates laser receiver.
8. Operating Mode Indicator - dual elevation shown.
9. Linked or Unlinked Elevation Mode icon. Unlinked shown.
10. Units of Measure - selected in User Setup.

6 Controls and Displays

6.4 LCD - Single Elevation / Slope Operating Mode

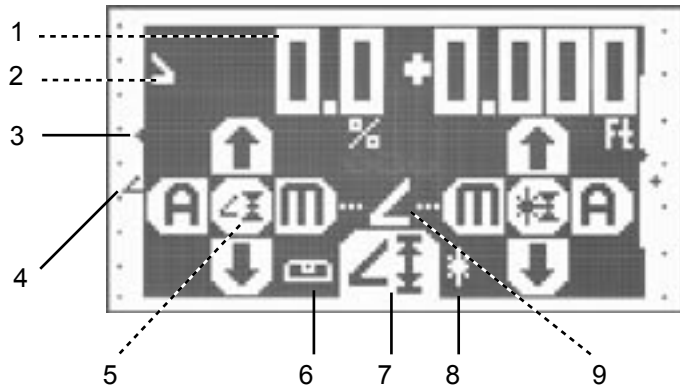

1. Slope Control Set Point Value - indicates the slope control set point. Value is referenced from the last horizontal bench.
2. Slope Control Set Point direction angle icon.
3. Slope Control Set Point - shows where on-grade slope is set with respect to slope range.
4. Sensor Position Indicator - shows position and direction of slope sensor reading.
5. Multi-switch function icon - pressing in enables slope matching and benching. Rotation changes slope control set point.
6. Control Source Indicator - bubble vial icon indicates slope sensor.
7. Operating Mode Indicator - single elevation and slope shown.
8. Control Source Indicator - starburst icon indicates laser receiver.
9. Slope direction after slope reverse (flip).

6 Controls and Displays

6.5 Sensor Position Window

Sensor Position Window - On-grade Set Range:

The on-grade set range is depicted by the indentation in the graphic. This range shows the limits of where the offset can be adjusted and where the on-grade set point can be located.

The on-grade set range will vary depending on the model of receiver used and the width of the deadband selected. The smaller the deadband, the larger the range. The larger the deadband, the smaller the range.

Areas above and below the set range are required for control.

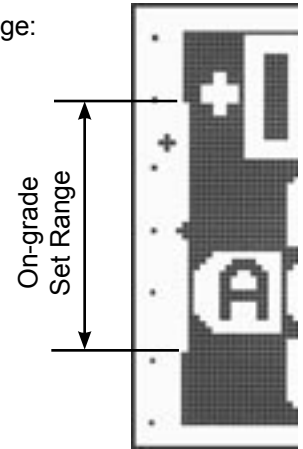

6.6 LED Grade Display

When a laser strikes the receiver or slope information is received, the control box LED's will indicate position information as follows:

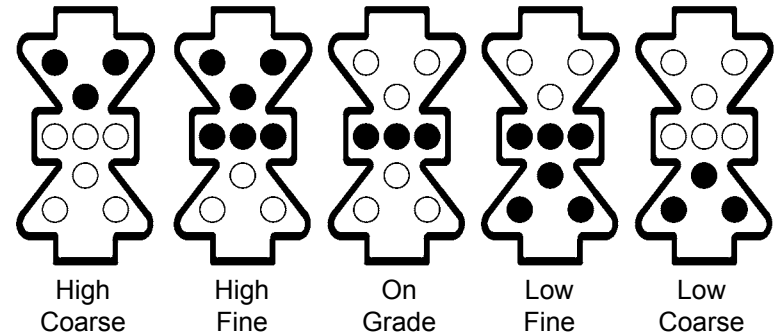

A laser out-of-beam will be indicated by a high or low flashing arrow directing which way to move the implement to locate the beam. After two minutes without a laser strike, only the center green LED will blink.

7 Operation

Ensure the receivers are connected to the system and toggle the power switch up to the ON (I) position to turn on.

The LED's and LCD of the CB52 will light up confirming power. The box checks that system components are present and responding correctly. If receivers or sensors are present, the LED's of the receivers will light in rows as a system check. If receivers or sensors are not present, a "No Sensors Found" message will be displayed.

If two sensors are connected, an LCD operating mode graphic will appear similar to the image below. If one sensor is connected, a single side will be displayed.

Power must be recycled if any laser receivers are added or removed.

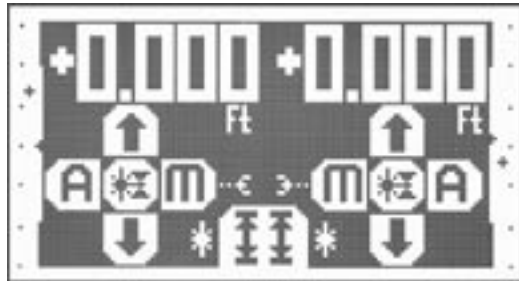

Operating Mode LCD

The CB52 can be switched between two modes:

- Operating Mode
- User Setup

Operating Mode is used for normal operating of the system. The operating mode screen shows system arrangement, what type of devices are connected to the system, switch functions, and additional operating information.

User Setup is used for adjusting the system. Selections include LCD brightness and contrast, deadband, valve speed, setting reference elevation, units of measure, and saving and recalling system settings. Refer to the User Setup section for details.

7 Operation

7.1 Select Operating Mode

The model of receivers installed will determine operating mode availability.



NOTE: The slope operating mode is available only if a slope sensor is detected. If detected on both sides selections are:



Elevation control left and right sides



Slope control left side / Elevation control right side



Elevation control left side / Slope control right side

If a slope sensor is detected on one side, only one side slope operating mode will be available.

To change the current operating mode, raise the power/setup switch to the up position and hold for approximately three seconds until the operating mode changes. Release the switch. Repeat the procedure until the desired operating mode is selected.

If a slope sensor is detected, a "Bench Slope Sensor" message will be displayed at power up as a reminder to bench the sensor to the machine. The message will clear in approximately 5 seconds or toggle the power switch upward to clear.

7.2 Slope Sensor Bench



NOTE: The internal slope sensors in the receivers are benched to horizontal at the factory. However, mounting mechanics, mast position, and other factors may create a difference in factory benching and actual blade slope. Receivers must be treated as unbent sensors prior to beginning work. To bench the slope sensor when mounted to the machine:

Level the cutting edge of the blade using a 4-foot spirit level.

Select Slope operating mode for the appropriate side.

Press in and hold the slope side multi-switch for 5 seconds.

The slope display will go to 0.0 degrees or 0.0 percent. The sensor position indicator and slope control set point will be positioned together.

7 Operation

7.3 Automatic / Manual



Automatic: Toggle the left multi-switch to the left (outward) and the right multi-switch to the right (outward) for automatic control. The switch will return to the neutral position. The green 'A' LED will turn on confirming that the side is in the automatic mode.

When the BULLSEYE receives a laser strike or slope information, the box will send the appropriate signals to the valve to raise or lower the implement to obtain and maintain an on-grade position. If the receiver is not receiving a laser strike, it must be moved within the reception range to begin corrections.

Manual: Toggle the left multi-switch to the right (inward) and the right multi-switch to the left (inward) for manual mode. The switch will return to the neutral position. The amber 'M' LED will turn on confirming that the side is in the manual mode. When the BULLSEYE receives a laser strike or slope information, the box will display the grade information on the LED's but will not send correction signals to the valve.

7.4 Raise / Lower



The left and right multi-switch raises or lowers the implement. When in the manual mode, the switch acts the same as a manual lever. To raise the implement, toggle the switch up. To lower the implement, toggle the switch down. When released, the switch will return to the center neutral position.

When the system is in the automatic mode, the manual raise and lower switch may temporarily override the automatic setting when it is activated and raise or lower the implement. When it is released, the automatic mode will resume normal operation.

7 Operation

7.5 Elevation / Slope Offset



Elevation Offset

The current blade position can be raised or lowered by rotating the multi-switch for the elevation side of the system. The reference elevation display will show actual elevation change. Clockwise rotation increases the elevation; counterclockwise rotation decreases the elevation.

If linked, both sides will change. If in Auto mode, the blade will begin to move. If in Manual mode, the blade will move when switched to Auto. The elevation control set point will move and show the location relative to the reception range. Elevation changes will stop when the set point gets to the outer limit. Receiver model, deadband selected, and location of control set point will affect the amount of elevation offset available.

Slope

The current slope can be increased or decreased by rotating the multi-switch for the slope side of the system. When in Auto, the slope position will move to the dialed in slope. The slope set point will move and show the location relative to the slope range.

7 Operation

7.6 Elevation / Slope Matching



Press in

Elevation Matching

Elevation matching allows an off-center laser strike to be set to on-grade.

When a BULLSEYE receiver is receiving a laser strike within the on-grade set range, pressing in and holding the corresponding elevation side multi-switch for approximately one second sets that position to on-grade. A single beep is emitted when accepted. The control box LED's and receiver LED's will show on-grade. The control set point will move to the current laser strike position. The reference elevation value will be reset to 0.00.

The on-grade elevation matching range will vary depending on the model of receiver used and the deadband setting.

If the on-grade matching is out of range for the receiver (usually when close to the outer edge of the photocell array) the control box will emit two beeps signaling the command was not accepted.

To reset the elevation to the default center on-grade location, press in and hold the multi-switch for five seconds. A second single beep is emitted when accepted. The elevation control set point will move back to the center position of the receiver and be depicted on the LCD. The reference elevation value will be reset to 0.00.

Slope Matching

Slope matching allows a current slope position to be set to on-grade.

When a BULLSEYE is receiving slope positioning information, pressing in and holding the slope side multi-switch for approximately one second sets that slope position to on-grade. The control box LED's and receiver LED's will show on-grade and the slope control set point indicator will move to the current slope position. The slope value displayed will be relative to the last horizontal bench. (See § 7.2)

If the slope matching is out of range for the receiver, the control box will emit two beeps signaling the command was not accepted.

7 Operation

7.7 Slope Reverse (Flip)



The slope function of the control box can be reversed about the horizontal benched position, or flipped. For example, switched from a left to right increase slope of 2.0% to a left to right decrease slope of 2.0%. This is useful when a slope is being graded and the machine is turned around 180 degrees to travel in the opposite direction.

To reverse the slope direction toggle both of the multi-switches inward to the manual position simultaneously and hold for approximately three seconds. The blade slope direction angle will reverse. For safety reasons, the system will revert to Manual mode if it is currently in Automatic mode. Select Automatic to move the blade to the flipped position.



NOTE: There may be large, quick movements of the blade when slope is reversed. Ensure there is ample clearance around the blade.

7 Operation

7.8 Link



Link enables changes to various settings on one side to cause the same changes to the other side.

In dual elevation operating mode, automatic/manual, lift raise/lower, elevation offset, elevation matching and elevation reset are linked for both sides when Link is activated.

In elevation/slope mode, automatic/manual, elevation and slope matching, and slope bench and elevation reset are linked when activated.

The Link function can only be turned on or off in dual elevation operating mode.

Before Linking, establish the desired position of the cutting edge to the laser plane (usually parallel).



To link the two sides, the dual elevation mode must be selected. Toggle both of the multi-switches inward to the manual position simultaneously and hold for approximately three seconds.

A linked chain icon will appear on the LCD confirming linked status. The linked chain icon will also appear if the operating mode is switched to the elevation/slope operating mode.



To unlink, the dual elevation mode must be selected. Toggle both multi-switches inward simultaneously and hold for approximately three seconds.

The unlinked chain icon on the LCD confirms the sides are unlinked.

7 Operation

7.9 Audio Alerts

An adjustable beeper on the rear of the control box housing emits an audible tone when switches are activated. Rotate the cover housing to adjust the volume.

A single short tone is emitted when an input is accepted. A double beep is emitted when an input is rejected or the laser beam is lost. A triple beep is emitted when the box is powered up.

7.10 Remote Switches

A single remote switch is typically used for Lift and Tilt applications. Dual remote switches are typically used for Dual Lift applications.

Remote switches are conventionally used for selecting Automatic or Manual control. They can be configured during installation to operate similar to the multi-switches on the control box. Automatic or manual, raise or lower implement, elevation/slope offset, and elevation/slope matching functions are options.

The switches are configured with the cable at the bottom when mounted and the switch facing inward so the thumb activates the switch. When mounted, toggle forward is Automatic, toggle backward is Manual. If raise and lower are available, toggle up is Raise, toggle down is Lower.

8 User Setup

User Setup allows selecting or changing the following settings:

- LCD brightness and contrast
- Deadband (accuracy)
- Valve speed (gain),
- Reference elevation values
- Units of measure
- Save and recall settings
- Lock settings

To access the user setup screen, toggle the power/setup switch to the up position and hold for approximately one second until the setup screen appears, then release.

The system will switch to manual mode if it is in automatic mode when the setup screen is selected.



User Setup LCD - Main Menu

The user setup menu is navigated with the left or right multi-switch.

Rotate or toggle the multi-switch until the desired function is highlighted. Press in the multi-switch to enter the selected function.

To exit the entered function, toggle the switch in any direction.

8 User Setup



Highlight the return icon and press in the multi-switch to return to the Operating Mode.



NOTE: Help screens are available in each selection. When in a particular menu, hold the power/setup switch in the up position to view the help screen. Release to turn off the help screen.



NOTE: When setting numeric values, clockwise rotation of the switch will increase the value; counterclockwise rotation will decrease the value.



NOTE: Numeric values depicted in the manual are for illustration purposes only.



8.1 Brightness / Contrast

Highlight the brightness icon and press in the multi-switch. A screen similar to the following appears. Brightness is on the left side. Contrast is on the right side.

Adjust until visibility is optimized.



Rotate the left multi-switch to change the brightness of the LCD and the LED displays. Changes are in increments of 5.

Rotate the right multi-switch to change the contrast of the LCD. Changes are in increments of 1.

The range of the brightness is 5 to 100.

The range of contrast is 0 to 100.

User Setup



8.2 Deadband (Accuracy)

Highlight the deadband icon and press in the multi-switch. If the system is configured without slope during installation, a screen similar to the following appears.



Rotate the left or right multi-switch to change the deadband. The deadband value will be applied to both sides

Maximum deadband width is 2.00 in (0.170 ft; 0.050 m).
BULLSEYE 3+ is 1.00 in (0.085 ft; 0.025 m).

If the system is configured with slope during installation, a screen similar to the following appears .



Rotate the left multi-switch to change the elevation deadband.

Rotate the right multi-switch to change the slope deadband. If slope sensors are not detected, the slope accuracy has no effect.

Maximum slope deadband is 5 degrees or 5.55% .



NOTE: Adjustment is for display deadband. Default control deadband is the same, but may be set smaller during installation.

User Setup



8.3 Valve Speed

Highlight the valve speed icon and press in the multi-switch. A screen similar to the following appears. Adjust the valve speed for optimum machine performance.



Rotate the right or left multi-switch to change the valve speed. Increase values to increase system gain; Decrease values to decrease system gain. Values are from 0 to 100%. The factory default setting is 50.



NOTE: Field adjustments to Deadband and Valve Speed may be necessary due to changes in system variables or jobsite requirements. Changing Deadband or Valve Speed may affect system stability. If the system becomes unstable, overreacting between above grade and below grade, increase the deadband setting or decrease the valve speed setting.

User Setup



8.4 Reference Elevation

Sets a reference elevation number for the elevation of the left or right side. Does not change elevation control set points. Adjust to match a known elevation or reference number.



Elevation or slope is shown depending on the operating mode selected. Slope may not be changed. Units are shown depending on the units selected.

Rotate the left multi-switch to change the left side reference elevation. Rotate the right multi-switch to change the right.



8.5 Units of Measure

Highlight the units icon and press in the multi-switch. A screen similar to the following appears. Slope units may not appear if slope option was turned off during installation.

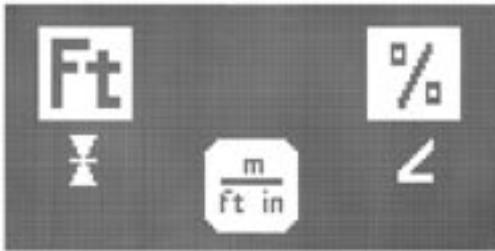

Rotate the left multi-switch to select the elevation units.

Rotate the right multi-switch to select the slope units.

Ft = Feet
in = Inches
m = Meters

User Setup



8.6 Store and Recall Setup

Highlight the save icon and press in the multi-switch. A screen similar to the following appears.

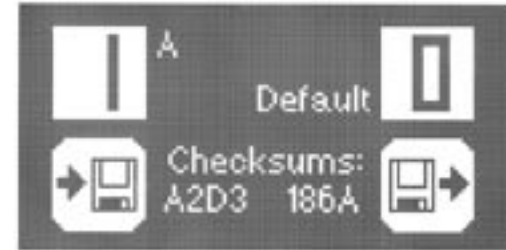

Store is on the left side. Storing a current configuration allows it to be recalled at a future time.

To store a current configuration, rotate the left multi-switch to the desired number 1 through 4. When selected, press in the multi-switch. A menu will ask if you would like to store. Select 'Yes' to store. Select 'No' to return to the previous menu.

If Yes is selected, a new name can be entered for the stored setting.

Rotate the multi-switch to scroll and stop on the desired character. Move the multi-switch to the right to allow selection of the next character. Continue until complete. Up to seven characters may be used. Once entered, the named setting will appear on the store and recall side for further use.

Recall is on the right side. To recall a stored configuration, rotate the right multi-switch to the desired number or name. Press in the right multi-switch. A screen will ask if you would like to recall. Select 'Yes' to recall and make the stored configuration the current configuration. Select 'No' to return to the previous menu.

Checksum values are displayed to check copied setups.

User Setup



8.7 Lock Setup

The current settings can be locked so that changes to certain settings cannot be made without unlocking.

Highlight the lock icon and press in the multi-switch. The icon will switch between locked and unlocked.



When locked, the following settings cannot be changed: deadband (accuracy), valve speed, elevation and slope matching, reference elevation values, units of measure, store and recall settings, and link sides.

If changes to these settings are attempted, a "Locked" note will appear on the screen.

9 Self Diagnostics

The CB52 provides fault codes and fault messages to assist in troubleshooting system problems.

When a fault is detected, a message appears on the LCD.

The fault can be cleared by pressing the multi-switch.

Power must be recycled to reset the drivers.

Contact your local dealer service department for troubleshooting support.

10 Specifications - CB52

Grade Display	Green On-Grade LED's Red High / Low LED's
Display	LCD
Operating Voltage	10 to 30 Volts DC, reverse polarity protected
Maximum Current	5 Amps per driver
Electrical Connection	Standard military type
Valve Compatibility	PT, Proportional Time (On/Off), PC, Proportional Current, and PV, Proportional Voltage
Laser Receiver Deadband	0 - 2.0 in. (0.05 in increments) (5.1 cm)
BE3+	0 - 1.0 inches (2.5 cm)
Slope Set Point Range	+/- 23 degrees (+/- 44%)
Remote Switch Option	Raise/Lower, Auto/Manual Multi-Switch Single switch for lift & tilt Dual switches for dual lift
Weight	5 lbs. (2.25 kg)
Dimensions (without knobs)	7.7 x 5.5 x 5.5 in. (196 x 140 x 140 mm)
Operating Temperature	-4° F to 140° F (-20° C to +60° C)

*Specifications subject to change without notice

11 Maintenance and Care

The user of this product is expected to follow all operating and safety instructions of this manual and of the machinery operator's manual.

Do not wipe dust or dirt off the receiver or control box with a dry cloth as scratching could occur. Use only soap and water with a soft cloth on all external surfaces and windows.

Transport the instruments in their original cases.

Inspect cables daily to ensure there is no excessive wear, especially at pivot points. Check for crimps or cuts in the wire insulation.

12 Warranty

Apache Technologies receivers and control boxes are warranted to be free of defects in material and workmanship for a period of two years. This warranty period is twenty-four months from the date the product is delivered from the dealer to the purchaser or is put into service by a dealer as a demonstration unit or rental unit. Electric cables and other allied equipment are warranted for a period of ninety days.

Please return the included warranty card as this will expedite any warranty service that may be required. Please retain your warranty information and proof of purchase. If a warranty card is not on file, proof of purchase must accompany your request for warranty repair.

Any evidence of abuse, misuse, alteration, accident or negligent use, or an attempt to repair products by unauthorized personnel or with parts other than those provided by Apache Technologies automatically voids the warranty.

The user of the product is expected to follow all operating instructions, periodically checking the instrument and the work as it progresses.

Apache Technologies liability under this warranty is limited to repairing or replacing any product returned to an authorized service center for that purpose. The foregoing states the entire liability of Apache Technologies regarding the purchase and use of its product and they shall not be held responsible for any consequential loss or damage of any kind.

This warranty is in lieu of all other warranties, expressed or implied, and constitutes all of Apache Technologies liability with respect to merchandise sold by it.