



8261 State Route 235
Dayton, Ohio 45424 USA
Phone: (937) 482-0200
Fax: (937) 482-0030
www.apache-laser.com

BULLSEYE™ 5

Laser Receiver

Thank you for purchasing an Apache Technologies, Inc. product. Your BULLSEYE™ 5 laser receiver is a premium quality tool that has been designed and manufactured to provide years of reliable performance. The receiver and accessories have been specifically designed for use in harsh machine mounted construction environments.

This manual is an important part of your purchase as it will familiarize you with the receiver and explain the numerous features that have been designed into it. Please read this manual thoroughly before using your receiver.

Please contact your Apache dealer or the Apache factory should you have questions regarding specific applications or if you require additional information.

Contact information is located on the back cover. Additional contacts are:

Website: www.apache-laser.com

Email: sales@apache-laser.com
service@apache-laser.com

Please record your product information below. This will assist you if there are any questions regarding warranty or service.

PRODUCT: _____

SERIAL NUMBER: _____

PRODUCT: _____

SERIAL NUMBER: _____

DATE OF PURCHASE: _____

PURCHASED FROM: _____

PHONE: _____

Warranty

Apache Technologies receivers are warranted to be free of defects in material and workmanship for a period of two years. This warranty period is twenty-four months from the date the product is delivered from the dealer to the purchaser or is put into service as a demonstration or rental unit.

Please return the included warranty card as this will expedite any warranty service that may be required. Please retain your warranty information and proof of purchase. If a warranty card is not on file, proof of purchase must accompany your request for warranty repair.

Any evidence of abuse, misuse, alteration, accident or negligent use or an attempt to repair products by unauthorized personnel or with parts other than those provided by Apache Technologies automatically voids the warranty.

The user of the product is expected to follow all operating instructions, periodically checking the instrument and the work as it progresses.

Apache Technologies liability under this warranty is limited to repairing or replacing any product returned to an authorized service center for that purpose. The foregoing states the entire liability of Apache Technologies regarding the purchase and use of its product and they shall not be held responsible for any consequential loss or damage of any kind.

This warranty is in lieu of all other warranties, expressed or implied, and constitutes all of Apache Technologies liability with respect to merchandise sold by it.

Maintenance and Care

Your BULLSEYE Laser Receiver was shipped in a moisture resistant foam padded carrying case. If the unit is transported from job to job inside its factory-provided case and normal instrument precautions are followed, the unit will provide many years of service.

Do not wipe dust or dirt off the laser receiver with a dry cloth as scratching could occur, possibly damaging these surfaces. Use only a good quality glass cleaner with a soft cloth on all external window surfaces. If these surfaces have hardened concrete or other materials on them, take the unit to your Authorized Service Center for cleaning.

If the system will not be used for a 30 day period or more, it is recommended to remove the batteries from the receiver. Space is provided in the carrying case for the storage of batteries.

Specifications

Beam Reception	360 degrees
Operating Range	2000 ft. (610m) radius, laser dependent
Laser RPM	Minimum - 105 ; Maximum - 1200
Vertical Reception Accuracy	6.75" (170 mm)
Cut / Fill Mode	Fine: 0.20" (5 mm) Standard: 0.50" (12 mm)
Excavator Mode	Standard: 0.50" (12 mm) Wide: 1.00" (25 mm)
Plumb Swing Range	± 2.5°
Display Output	Bright or Dim
Power Options	Alkaline - 4 x "C" Cell - Standard Nickel Metal Hydride - 4 x "C" Cell Power Cable - 10-30 VDC
Battery Life - Alkaline (Continuous in beam)	75 Hours, Display Dim 50 Hours, Display Bright
Battery Life - NiMH (Continuous in beam)	55 Hours, Display Dim 40 Hours, Display Bright
Battery Recharge Time	3 - 4 hours
Automatic Shut Off	75 minutes with no laser beam
Out of Beam Indication	High and Low
Remote Display Option	Yes
Automatic Control Option	Yes
Dimensions	(LxWxD) 13.50" x 5.58" x 5.88" (343 x 142 x 149 mm)
Mounting Pipe	1.66" to 2.00" O.D. round tube (42 mm to 50 mm) and 1 1/2" (38 mm) square tube
Operating Temperature	-4° F to 140° F (-20° to +60° C)

Contents

BULLSEYE 5 Laser Receiver

Contents	1
Safety	2
System Description	3
Controls and Displays	4
Battery Installation / Charging	6
Operation	8
Installation and Set-Up	11
Specifications	16
Maintenance and Care	Inside Back Cover
Warranty	Inside Back Cover

Safety

Meaning of Symbols:



WARNING: Indicates a potential hazardous situation, which could result in death or serious injury.



CAUTION: Indicates a potentially hazardous situation, which could result in a minor or moderate injury and/or material, financial, or environmental damage.



NOTE: Important information to enable the product to be used in a correct and efficient manner unrelated to safety.

The user of this product is expected to follow all operating and safety instructions of this manual and of the machinery operator's manual. Perform periodic checks of the product's performance. The manufacturer or its representatives assume no responsibility for results of the use of this product including any direct, indirect, consequential damage, and loss of profits. Check your work frequently.



WARNING: When working near construction or agricultural machinery, follow all safety precautions as described in the machinery's user manual.



WARNING: When excavating, follow all excavation and trench safety regulations and practices



CAUTION: Be aware of all overhead obstructions and electrical power lines. The receiver and mast may be higher than the machinery. Remove when transporting machinery.



CAUTION: Do not disassemble any part of the receiver other than to replace batteries. The receiver is to be serviced by authorized Apache Technologies service personnel only.

System Description

The Apache BULLSEYE 5 laser receiver is a rugged, multipurpose, electronic receiver that detects laser light generated by rotating laser transmitters. The unit is designed to work with nearly all makes and models of rotating lasers and will detect both visible and invisible beams.

When installed, the operator is given visual indication of the reference plane of laser light's position relative to the cutting edge of the machine. The BULLSEYE 5 can also be installed with an Apache Control Box for automatic control on certain grading machines. The features and versatility built into the BULLSEYE provide a product that can increase the utilization and productivity of many different types of construction and agricultural machinery.

The operator can customize the settings of the BULLSEYE to meet job site requirements. Settings are provided for adjusting the deadband size or accuracy, the location of "on-grade" for grading or excavation, the display for bright or dim conditions, and a laser out-of-level warning.

The ultra-bright, built-in LED display provides up to 7 channels of grade elevation position, plus high and low lost beam indications.

A tough sealed waterproof housing is designed to work in the tough machine mounted environment. The electronics are isolated from the rest of the unit by internal rubber shock-mounts, protecting the unit from shock and vibration damage.

Controls and Displays

1. Aluminum cast upper and lower housings.

2. Polycarbonate housing - protects the electronics.

3. Receiving Window - four sets of photocells equally spaced to allow 360 degree reception.

4. Ultra-bright LED array is highly visible - graphically displays the blade or bucket position.

5. Power Switch turns the unit on and off.

6. Grade location, battery status, and deadband LED indicators.

7. Touchpanel Switches allow adjustment of accuracy, on-grade location and plumb indication, laser out-of-level warning, and brightness. Refer to page 8 for details.

8. Mounting Knobs - large, front facing knobs attached to stainless steel clamps allow for quick and easy installation to mast or magnetic mount.

9. Access screws - allows easy access to battery compartment for replacement of batteries.

10. Accessory Connector and Dust Cap - connector accepts the cable connection to the optional remote display, machine power cable, or automatic control box. Connector is also accepts Ni-MH battery charger. Dust cap helps keep the connector clean.

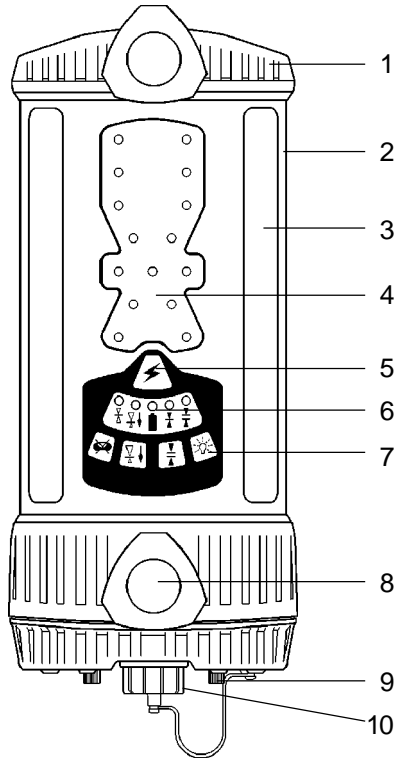

Controls and Displays

LED Status Indicators

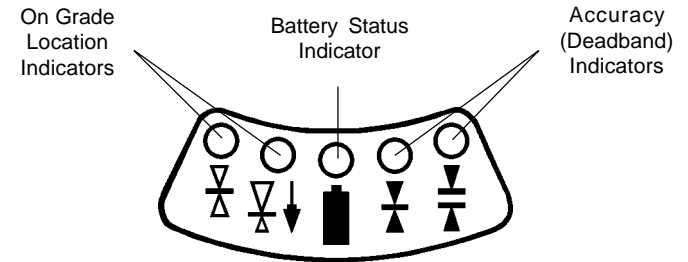

Switch Panel

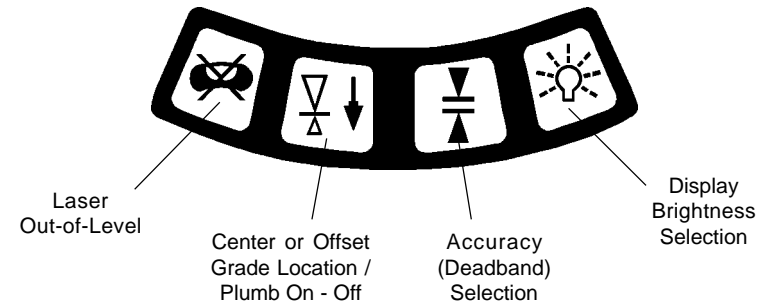

The initial or default settings when the receiver is turned on are:

Laser Out of Level (OOL)	Off
Grade Location	Last Set
Deadband	Last Set
Brightness	Last Set

Battery Installation / Charging

Alkaline Battery Installation: Remove the BULLSEYE from its carrying case. Hold the unit so the accessory connector is pointing upwards. Remove the dust cap from the accessory connector. Loosen the two thumb screws and remove the battery access cover. Install four "C" cell alkaline batteries as shown on the label diagram inside the battery compartment noting the (+) and (-) terminals.

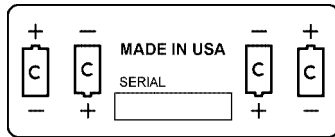

Battery installation diagram /
Serial number label

Replace the battery access cover. Firmly tighten the two thumbscrews. Replace the accessory connector dust cap.

Nickel Metal Hydride Batteries: Rechargeable batteries require an initial and subsequent charging time of approximately 3 hours. It may require 2 or 3 charging cycles to obtain maximum battery life. To charge, remove the dust cap from the accessory connector. Insert the cannon adapter into the accessory connector and tighten. Insert the charger into the cannon adapter. Plug the charger into a 110-volt outlet. (European and Australian chargers allow plugging into appropriate outlets.)

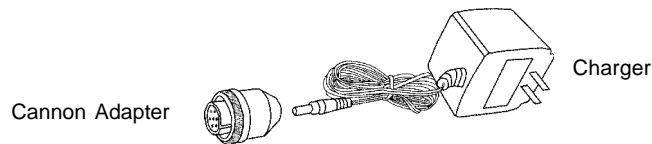

The batteries may also be charged with a 12-volt auto cigarette lighter adapter. The charge status indicator located on the back of the housing will remain solid when the unit is charging. The indicator will blink when fully charged. When charged, unplug the charger from the outlet and remove the cannon adapter from the accessory connector.

Battery Installation / Charging

Built-in overcharging protection prevents damage if the unit is left on charge after being fully charged. There is also charge protection for attempting to charge alkaline batteries.



CAUTION: Do not attempt to charge alkaline or other disposable batteries.



NOTE: Do not charge Ni-MH batteries when ambient temperature exceeds 113 F° (45°C).

The rechargeable battery electronics include a charge error indicator. A solid light on the right LED indicates an error with either the internal battery connection, the charging temperature, or possible dead battery cell. Contact your dealer service department if this light is displayed.

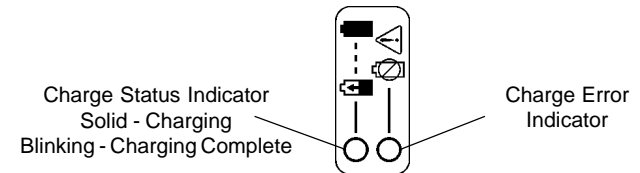

Rechargeable Battery Replacement - Remove the battery access cover. A battery contact is located in the battery housing as illustrated. For proper operation, a negative end of one rechargeable battery must have the protective cover removed or "skinned" and positioned to touch the contact in the housing as illustrated. Follow the label diagram for the other batteries. Replace with factory approved NiMH batteries only. Once installed, replace the battery access cover, firmly tighten the two screws and replace the dust cap. Charge as instructed on page 6. Refer to your local requirements for the proper disposal of rechargeable batteries.

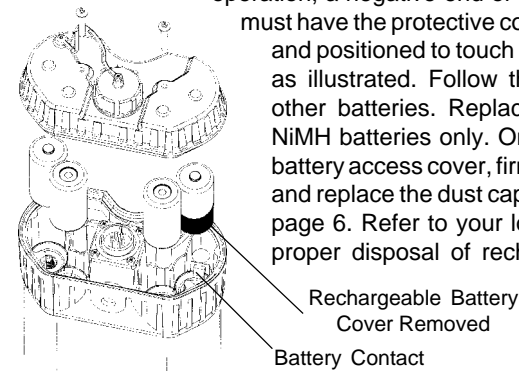

Operation



Power: Press the power switch on the touch panel to turn the unit on. All the LED's will light briefly and then each LED row will light from top to bottom. This also acts as a check to assure the display is working properly. On-grade location and deadband settings are retained from the last time the unit was turned off. If the receiver is out of the laser beam, the center light will flash to confirm power is on. If the receiver is in the laser beam, the corresponding LED grade display will be indicated. To turn the power off, press and hold the power key for approximately 2 seconds until the LED's are lit, then release the switch.



Laser Out-of-Level Switch: Used with rotating lasers that change their RPM's when out-of-level. This function is always disabled (off). Pressing this switch once turns the function on. The LED array will display an "X" to confirm it is enabled. When out of the laser beam, the "X" will flash. When beam strikes greater than 140 RPM are received, it operates normally. When beam strikes less than 140 RPM are received, it will toggle between an "X" and the appropriate grade display. To turn the function off, press the switch again, and an "X" without the center LED will display indicating the function is disabled.

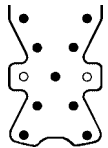

Out of Level
Enabled



Out of Level
Disabled



Center / Offset On-Grade Switch: Center on-grade is selected for typical grading or cut/fill operations. This mode indicates an equal amount of grade information above and below on-grade. Offset on-grade is selected when using a backhoe or excavator. The excavation mode gives more information and a larger display area above on-grade. This mode also enables the plumb indication which shows the operator when the mast and receiver are perpendicular to the ground (plumb) for more accurate grade readings. Pressing the switch once lights the LED of the current selection. Pressing the switch again while the LED is on changes the selection.

Operation

Center / Offset On-Grade Switch:



Center
On-grade
Selected,
Plumb Off



Center
On-grade
LED's used



Offset
On-grade
Selected,
Plumb On



Offset
On-grade
LED's used

Plumb Indication: The plumb indication shows when the mast and receiver are perpendicular to the ground or beyond the deadband range of +/- 2.5 degrees. The LED's will flash quickly when the boom is extended, and will flash slowly when the boom is retracted beyond this range. The LED display is solid when the boom is within the plumb range.



Deadband (Accuracy) Switch: Two choices are fine and standard in the grading mode and standard and wide in the excavating mode. The LEDs are used to show current selection. This selection and the center / offset on-grade selection will determine the deadband. Pressing the switch once lights an LED of the current selection. Pressing the switch again while the LED is on changes the selection.



Grading



Fine
1/4"
(5mm)



Standard
1/2"
(12mm)



Excavating



Standard
1/2"
(12mm)



Wide
1.0"
(25mm)

Operation



Display Brightness Switch: Selects the LED display brightness. Bright and Dim are the options. Use Dim for normal and lower light conditions and Bright for sunny daytime operation if necessary. Display Dim will conserve battery life

by approximately 50%. When the switch is pressed with the receiver out of the laser beam, the LED's will display a circle with the current setting. Depress the brightness switch again while the LED's are lit to change the setting. When receiving a laser beam, simply press the switch and the setting will change. Viewing the LED's directly in front of the receiver optimizes the brightness.

Out of Beam Indication. The LED display will indicate if the receiver has moved beyond the vertical reception range. A sequence of LED's will indicate which direction the cutting edge must be moved to pick up the beam. The out of beam indication will turn off in approximately two minutes if no beam is received.

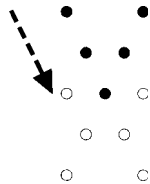

Sequence to lower implement

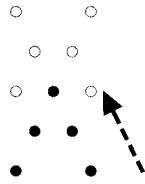

Sequence to raise implement



Low Battery Indicator: The receiver has a low battery warning LED that is used when batteries are installed. During normal operation with good batteries, the LED is off. When the batteries become low, the LED will begin to flash. The unit will operate as normal with

approximately 90 minutes of battery life remaining. When the batteries are too low to operate, the LED will be on continuously and the four corner grade display LED's will toggle on and off indicating the batteries must be replaced or charged if using Ni-MH batteries.

Installation - General

Set up the laser in a convenient, safe location. Please refer to your laser operator's manual. Ensure the laser is on a stable tripod. On windy, gusty days it may be advisable to tie down or weigh down the tripod to make the laser beam more stable.

Operating distances are dependent upon the rotating laser power. The receiver can pick up the beam from all directions (360°), but still requires a clear line of sight between the laser and receiver.

If your laser has selectable rotation speeds, select a high rotation speed. The receiver can process speeds up to 1200 RPM.

To mount the receiver on a mast, turn both the top and bottom knobs counterclockwise until the mounting clamps in back open enough to fit around the mounting mast. Place the receiver on the mast. The receiver will mount to round tubing that has a 1.66" to 2.00" outside diameter (42 to 50 mm) or to 1 1/2" (38 mm) square tubing. Turn the knobs clockwise to tighten. Loosen the two clamps to remove the receiver from the mast.



WARNING: Follow all safety precautions per the machines operator's manual and follow all excavation and trench safety requirements and practices.

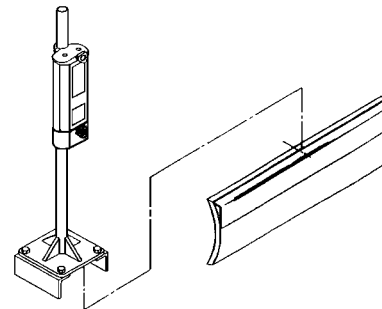

Typical Dozer Installation

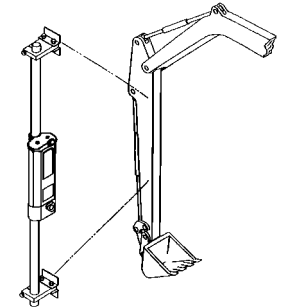

Typical Excavator Installation

Installation - Grading

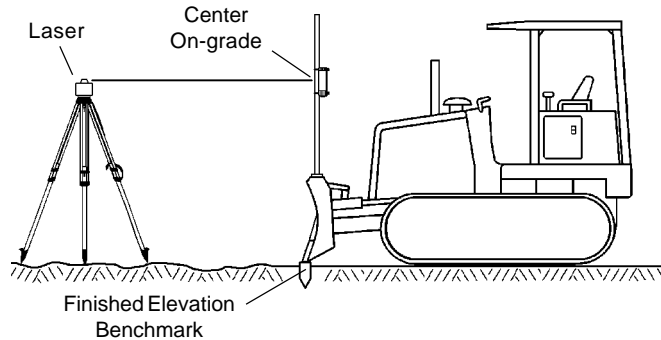

Position the machine so the blade is set to the desired finished elevation, typically on a benchmark or hub stake.

Set the laser up in an appropriate location for receiver visibility and efficient machine operation and turn it on.

Turn the receiver on, select center on-grade (grading mode) and select the smallest deadband.

Mount the receiver to the mast.

Slide the receiver up or down until on-grade is indicated. It may be necessary to adjust the height of the laser.

Alternatively, if the height of instrument (laser beam) to finished elevation length is known, the receiver can be set by measuring this distance from the cutting edge of the blade to the center on-grade mark on the back of the receiver label.

Face the LED grade display toward the operator and tighten the clamps.

Select the desired deadband and brightness.

The LED grade display will direct the operator which way to move the blade using the machine's controls to maintain an "on-grade" reading.

Make a sample pass with the blade "on-grade" and check to ensure the elevation is correct.

Installation - Excavating

When using on an excavator or backhoe, the dipperstick should be vertical and the bucket positioned so it can easily be repeated each time a grade reading is taken. The bucket can be fully extended, curled, or levelled, as long as it is consistent when grade readings are taken. The receiver can be set-up in the trench or out of the trench if the cut elevation can be determined.

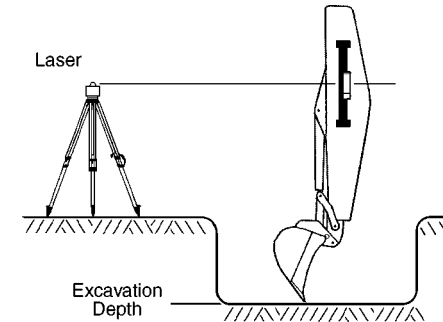

In Trench Set-Up

Position the machine and dig to the desired finished elevation.

Position the bucket in the grade checking position at the finished elevation.

Set the laser up in an appropriate location for receiver visibility and efficient machine operation and turn it on.

Mount the mast on the side of the dipper arm.

Turn the receiver on and select the offset on-grade and the smallest deadband.

Place the receiver on the mast, tighten, and adjust the dipper arm so the receiver is within the plumb range - solid LED's.

Slide the receiver up or down to get an on-grade display then tighten. (The center on-grade location may be selected and set at this time).

Select the desired deadband and begin to excavate.

Take grade readings with the bucket in the grade checking position and the LED's solid.

Take a sample reading with the bucket "on-grade" and check to ensure the elevation is correct.

Installation - Excavating

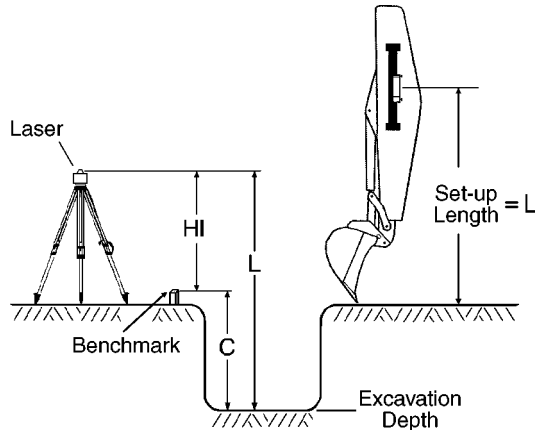

Out of Trench Set-Up

Set the laser up in an appropriate location for receiver visibility and efficient machine operation and turn it on.

Place the bucket in the grade checking position and situate the machine so a measurement can safely be obtained on the dipper arm. The dipper arm may be set more horizontal to the ground for convenient measurements if necessary.

Determine the distance from the laser to the bottom of the trench (L). This is the set-up length. The length is the height of the instrument (HI) plus the depth of cut from the benchmark to the bottom of the trench (C).

Mount the mast on the side of the dipper arm.

Position the receiver so the set-up length (L) is the distance from the bucket ground contact point to the offset on-grade symbol on the back label. (Set up to center on-grade symbol if center on-grade will be used).

Turn the receiver on and select offset on-grade and the desired deadband. (Select center on-grade if set to center symbol).

Begin to excavate. Take grade readings with the bucket in the grade checking position and the LED's solid.

Take a sample reading with the bucket "on-grade" and check to ensure the elevation is correct.

Installation - Magnetic Mount

For excavators and backhoes, determine where the mount will be located on the machine so that when the BULLSEYE is attached, it will intersect the laser beam. Ensure the area of the machine is clean and free of oil and grease. Angle the mount so the top edge of the top magnet will be positioned first. Holding the mount by the pipe with both hands, place the top edge of the magnet on the machine. Slowly move the bottom magnet towards the machine so the mount remains plumb.



CAUTION: Strong magnetic field; Do not position fingers next to magnets.

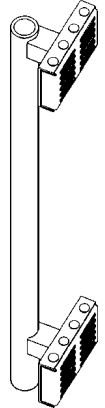

Attach and set-up the BULLSEYE in the normal manner as described on the previous pages.

Remove the receiver from the mounting pole prior to removing the magnetic mount. Use a scrap piece of wood or other long material as a pry bar. Insert the pry bar in between the magnetic mount pole and the machine. Pry the mount sideways to loosen the magnetic hold. Once the magnetic hold is loosened, the mount can be easily taken off the machine by hand.



NOTE: For extendable dipper arms - if the mast is mounted to the dipper arm section that moves with the bucket, grade can be checked with the dipper arm extended to any position. If the mast is mounted to the dipper arm section that does not move with the bucket, grade can only be checked when the dipper arm is in the exact set-up position.