

**INSTRUCTION MANUAL**

**BEAR**<sup>TM</sup>  
S C I E N T I F I C

**MULTI LINE LASER**

model: **SERVO 360HP**

**INDOOR/OUTDOOR**



***Thank you for purchasing the Bear Servo 360HP multi-line laser.***

For trouble-free use of the instrument, please read this instruction manual carefully and keep it for future reference.

**FOR YOUR RECORD**

Place of Purchase : .....

Date of Purchase : ...../...../.....

# Contents

Chapter 1.	Instrument accessories .....	Page 3
Chapter 2	Cautions .....	Page 4
Chapter 3.	Functional description .....	Page 5
Chapter 4.	All laser line functions .....	Page 7
Chapter 5.	Instrument layout.....	Page 8
Chapter 6.	Touch panel controls .....	Page 9
Chapter 7.	Operation .....	Page 10
Chapter 8.	Manual slope mode .....	Page 11
Chapter 9.	Specifications.....	Page 15
Chapter 10.	Automatic energy saving feature .....	Page 16
Chapter 11.	Care & maintenance .....	Page 17
Chapter 12.	Optional accessories .....	Page 18

# 1. Instrument accessories

## Standard accessories

1. Instrument
2. Aluminium carrying case
3. Instruction Manual
4. Laser Glasses
5. Ni-MH batteries (4 x AA)
6. Red Laser Target
7. B-CHRG smart charger

## Optional accessories

*pictures page 18*

1. Multi Function Tripod B-MFT
2. Laser Line Outdoor Receiver and Clamp B-LLR
3. Wall Mount B-WM
4. Laser Pole LP12-LL

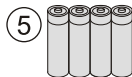
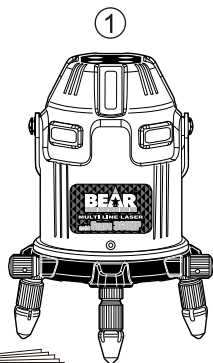
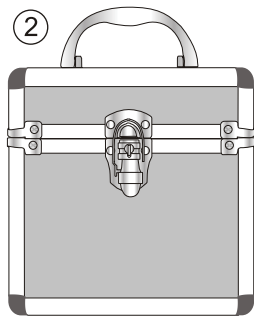

## 2. Cautions

1. The Servo 360HP is classified as a class 2M/2a laser product according to United States Government Code of Federal Regulations CFR21.
2. **Avoid direct eye exposure to the laser beam.**
3. When moving the instrument please turn off the power.
4. Push the buttons on the top of the Servo 360HP with the base of your finger, not sharp fingernails.
5. When the Laser is not being used for periods greater than 1 month please remove the batteries from the unit to avoid corrosion.
6. Maximum operating time will be achieved by always using good quality Alkaline batteries. If you are using Ni-MH batteries, charge them in the B-CHRG smart charger. DO NOT attempt to charge Alkaline batteries.

### **3. Functional description**

1. The Servo 360HP produces four visible Vertical lines all at 90° to each other, one 360° Horizontal line for checking levels, and a plumb point down. All four Vertical lines wrap up the walls and onto the ceiling to produce a cross directly above the unit for plumb setting applications. (See diagram on page 7 for all functional laser beams).
2. The Servo 360HP features bright, visible beams for indoor work but can also be used outdoors with the optional B-LLR receiver giving the user a working range of up to 80m.
3. The unit is fully self-leveling within  $\pm 5^\circ$  and features an electronic Servo compensator to ensure fast leveling & consistent accuracy at all times.
4. If the Servo 360HP is set up outside of it's self-leveling range, the laser beams will flash - do not take readings.

### **3. Functional description (continued)**

5. A 360° infinite adjustment slow-motion tangent screw enables the vertical laser lines to be set easily and accurately for turning right angles to the target.
6. When power is turned off the compensator is locked automatically to avoid damage due to vibration while in transport.
7. The horizontal line can have a slope manually induced in both axes for grade matching, drainage & other dual slope applications.

#### 4. All laser line functions

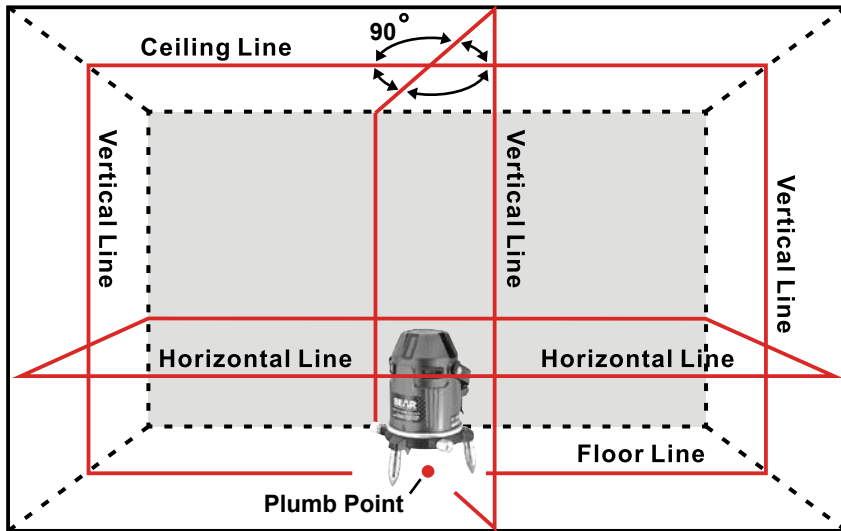

**SERVO 360HP**

## 5. Instrument layout

1. Touch panel
2. Vertical laser windows
3. Horizontal laser windows
4. Carrying belt
5. Horizontal slow motion tangent screws
6. Battery cover
7. Leveling screw
8. 5/8 x 11 female thread incorporating plumb down laser point

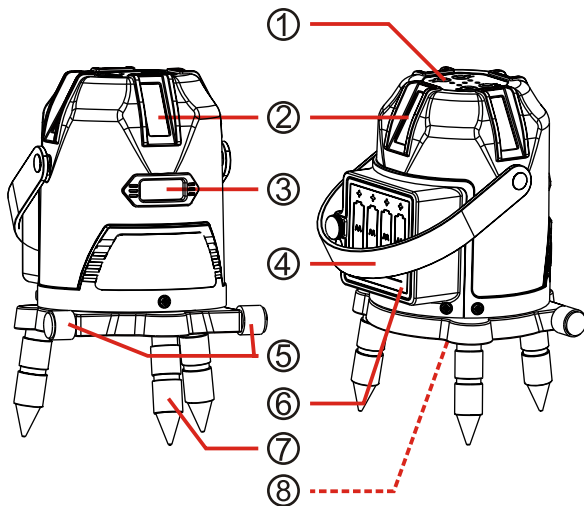

## 6. Touch panel controls

1. Laser beam (Horizontal) LED
2. Horizontal button
3. Power button
4. Power LED  
(Green light turns to red when power is low)
5. Laser beam (Vertical) LED
6. Vertical button
7. Leveling indication LED
8. Outdoor receiver button
9. Receiver LED  
(If the green LED is on, the function is in use)

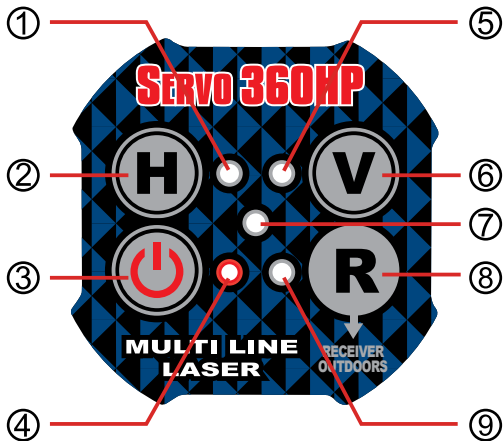

## 7. Operation

1. Open the battery compartment and insert 4 x Alkaline or rechargeable batteries in the correct order (+/-). Close the battery cover and screw tight. If the unit does not turn on check battery voltage and polarity.
2. Place the Servo 360HP on the floor, countertop or mount it to a tripod, laser pole etc.
3. Press the power button. This will power up the instrument and activate the self-leveling servos. The leveling indication LED will flash while the unit is leveling and then remain ON steady once leveling is complete.
4. If the Servo 360HP is setup outside of it's self-leveling range, the laser beams will flash. Use the 3 leveling screws (or the tripod legs) to adjust the unit to approximately level. The instrument will now self-level and the beams remain ON steady.
5. When first switched on, the laser will have only the front vertical line and plumb down dot switched on. Use the H & V buttons to cycle through the various horizontal and vertical beams equipped to the laser as displayed on page 7.
6. Pressing the outdoor receiver button will put the laser into pulse mode (receiver LED will turn on) so that it can be used with the optional laser line outdoor receiver (B-LLR). Pressing the button a second time will put the unit in a power-saving pulse mode that conserves battery life by reducing the working range of the beam (the receiver LED will flash). Pressing the outdoor receiver a third time will return the Servo 360HP to normal, visible, indoor operation.

## 8. Manual slope mode

### Notes:

- When in slope mode all self-leveling & compensation is disabled
  - If the laser is to be used with the B-LLR Receiver while in manual slope mode it must be placed in pulsed mode by pressing the R button prior to entering manual slope mode as described below.
  - We suggest the Genno Rod is used for setting the grade as it is graduated in mm on both sides. If using the cut/fill side, then simply set the Rod and receiver to zero (0) & then to set the grade move the sliding section up or down the required distance as per sample
  - Also remember to hold the red vertical (use the inbuilt bubble) otherwise the grade will be incorrect.
1. To enter manual slope mode:
    - Hold the power button for 2-3 seconds.
    - All H lines & the front V line will turn on.
    - The H, V & Leveling Indication LEDs will all be lit, showing that the unit is in X-axis slope adjustment mode (see Fig. 1)
  2. While in X-axis slope mode:
    - press and hold the H button to drive the laser line up in the +X axis.
    - Press and hold the V button to drive the laser line down in the +X axis.

3. Press R to switch the unit to Y-axis slope mode.
  - The V, R & Leveling Indication LEDs will all be lit, showing that the unit is in Y-axis slope adjustment mode (see Fig. 2)
4. While in Y-axis slope mode:
  - press and hold the R button to drive the laser line up in the +Y axis.
  - Press and hold the V button to drive the laser line down in the +Y axis.
5. Press the H button to switch back to X-axis slope mode. The unit can be switched between X & Y axis slope mode as many times as you wish.
6. During the above procedures there is a limit to the amount of slope that can be driven into either the X or Y axis. When this limit is reached the laser lines will flash & no further slopes can be achieved.
7. Press the power button to reset any slopes and return the unit to self-leveling mode



Fig 1

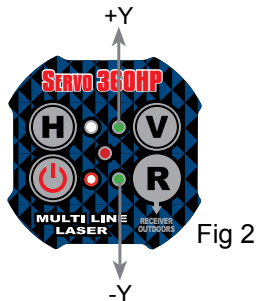

Fig 2

## Annex A:

### Setting up for a manual grading application:

Note: • **Warning!** Do not disturb the setup of the laser while taking elevation readings. The laser is completely manual in this mode and any shifts will result in movement of the laser plane. This method of creating a slope/grade is not recommended for precision applications. Bear Scientific are not responsible for any mishaps that may result by following the process described below.

1. Setup the Servo360HP, turn it on and allow it to self-level.
2. Rotate the unit in such a way to align the X and Y axis in the direction of the desired slope(s) using the vertical beams.
3. Establish a point (**Point A**) at a known **horizontal** distance along the desired run of the axis in which you wish to set-up a grade. You can use a staff, a stake, a tape measure, a wall or a Genno Rod.

(Note: The point should be set at an easily calculable distance to make measurements and calculations easier. Example: 10 metres)

4. Calculate the **Height Differential** for your desired slope/grade as per the following formula:

$$\text{Height Differential} = (\text{slope } \%) \times (\text{distance})$$

*(See example below)*

5. Take a “level” reading at **Point A** and make a mark.
6. Enter **manual mode** and use the manual grade controls to tilt the plane of light (as per instructions in chapter 8) until the difference between the “slope” reading at **Point A** and the original “level” reading at **Point A** is equal to the **Height Differential** as calculated in point 4 above.

7. Perform steps 3 to 6 in the opposite axis for dual grade applications.

**Example:** You desire a positive 2% slope and **Point A** is 10m from your laser.

Eg: +2% Slope with **Point A** 10 metres from the laser. (Note: 2% = 2/100)

$$\begin{aligned}\text{Height Differential} &= (\text{slope } \%) \times (\text{distance}) \\ &= (2\%) \times (10\text{m}) \\ &= (2/100) \times (10\text{m}) \\ &= 0.200\text{m}\end{aligned}$$

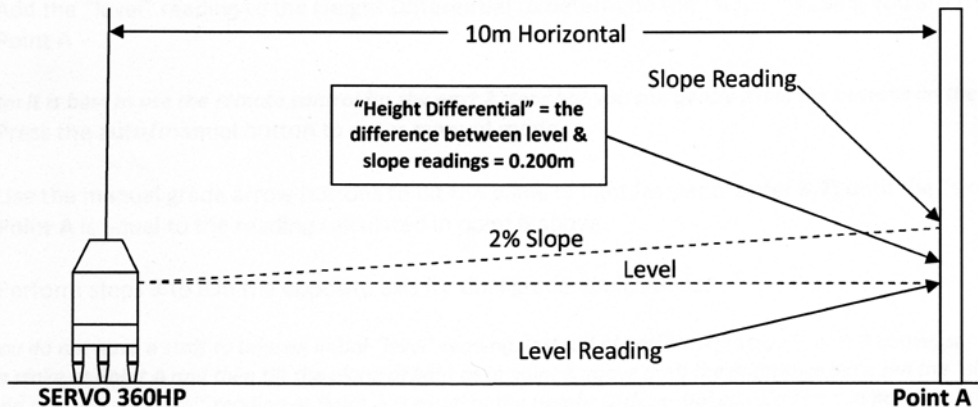

## 9. Specifications

Model no.	<b>SERVO 360HP</b>
Light sources	635nm laser diode / floor point 650nm
Laser safety class	Class 2M / 2a
Anti-dust & water	IP-54
Accuracy	$\pm 1\text{mm}/10\text{m}$
Self-leveling range	$\pm 5^\circ$
Working range(with detector)	80m
Rotation/Fine adjustment	360° rotation / 360° fine adjustment mechanism
Power supply	4 X AA batteries / rechargeable batteries / AC adaptor
Service time	Approx 5~10 hours with all lines ON.
Mounting thread	5/8" x 11 female
Operating temperature	-10°C ~ +40°C
Weight	1.9kgs
Size	∅152X223mm

## **10. Automatic energy saving feature**

1. This instrument automatically detects battery voltage. When full power cannot be used it will reduce output power to 60%. The Power LED will turn red.
2. If the battery is unable to supply 60% power, the instrument will switch to 30% output power and the Receiver LED will flash green.

## 11. Care & Maintenance

1. If the instrument is opened (cover removed) by anyone other than an authorised service centre, warranty will be void.
2. Avoid dropping the unit or shaking it as there is a possibility that the accuracy will change. If the instrument has been dropped please return it to your dealer for calibration (charges may apply).
3. If you are not going to use the Servo 360HP for a period greater than 1 month please remove the batteries from the unit.
4. To clean the instrument, please use a soft cloth with mild soap.
5. Do not use harsh chemicals, cleaning solvents or detergents to clean the Servo 360HP.
6. To clean the glass windows please use lens tissues.
7. If the unit is wet please towel dry and let all water evaporate before placing it in it's carrying case.
8. Only use good quality Alkaline batteries or Ni-MH which have been charged externally using the B-CHRG smart charger.

## 12. Optional accessories



### 1. Laser Line Outdoor Receiver and Clamp

model B-LLR

- Display: 3 channel LED
- Reception height: 22mm
- Audio settings: mute, low, high
- Built-in level vials for vertical & horizontal work
- Rugged, heavy-duty aluminium rod clamp
- Battery: 9V



### 2. Multi Function Tripod

model B-MFT

- Telescopic centre rod – range 450mm
- Flat head – 5/8 x 11 male thread
- Large support disc for all laser, optical instruments
- Safety chains
- Fully extended tripod 2070mm, collapsed height 970mm
- 2 types of points **included** indoor (rubber), outdoor (steel points)
- Hole in centre allows laser dot to be seen on the ground

## 12. Optional accessories (continued)

### 3. Laser Pole model LP12-LL

5 section, 32mm diameter pole, extends to total **3.6m ht.** Adjustable platform throughout whole height with 5/8 x 11 male thread. Includes carry bag (750mm), holds all 5 sections incl adjusting platform. (Four screw in sections at 600mm, the 5th section adjusts from 600 to 1360mm). These sections can be used in any combination to a max of 3.6m from floor to ceiling. The laser pole is ideal for cross lasers, dot lasers and small rotational lasers.



### 4. Wall Mount model B-WM



- ### 5. Genno Rod Model B-GENNO
- Two rods in one. Extended height 3.7m. Cut & fill on front, conventional rod on back, all in mm. Includes carry bag and bubble. A great choice for distances up to 30-40m. Use with laser receiver or optical dumpy level.



5. Bear Small Elevating Tripod  
model B-SET

- Height when closed 15cm
- Height when fully extended 26cm
- 5/8 x 11 thread
- Optional camera thread adapter available



6. Bear Large Elevating Tripod  
model B-LET

- Height when closed 56cm
- Height when fully extended 146cm
- 5/8 x 11 thread
- Optional camera thread adapter available







**AUTHORISED DEALER:**